

iArmor®

IARMOR EDGE™

PART#: IA-N179&N208&N209

BEFORE INSTALLATION

REMOVE CONTENTS FROM BOX. VERIFY ALL PARTS ARE PRESENT. READ INSTRUCTIONS CAREFULLY BEFORE STARTING INSTALLATION. ASSISTANCE IS RECOMMENDED. THANK YOU FOR CHOOSING OUR PRODUCT!

*ROCKER PANEL MOUNT

*DRILLING MAYBE REQUIRED

Fastener Size	Tightening Torque (ft-lbs)	Required
6mm	6-7	√
8mm	16-18	√
10mm	31-32	X
12mm	56-58	X
14mm	92-94	X

Driver

Front

Passenger

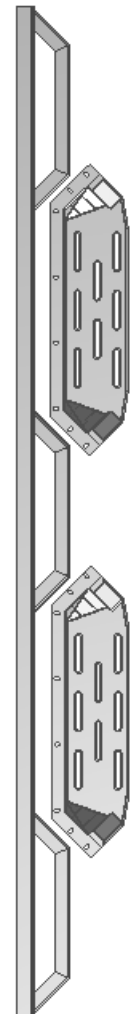
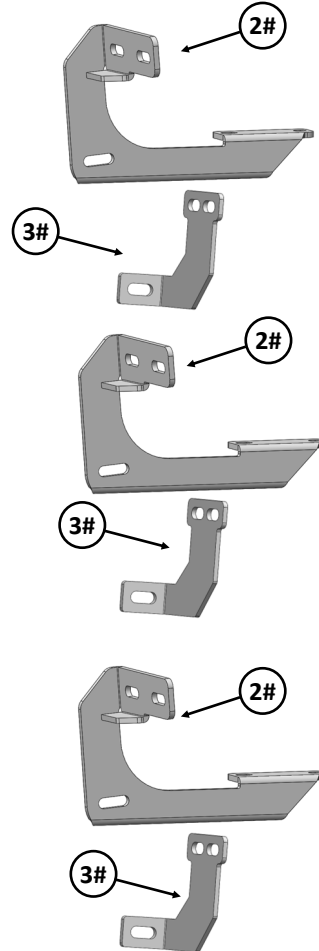
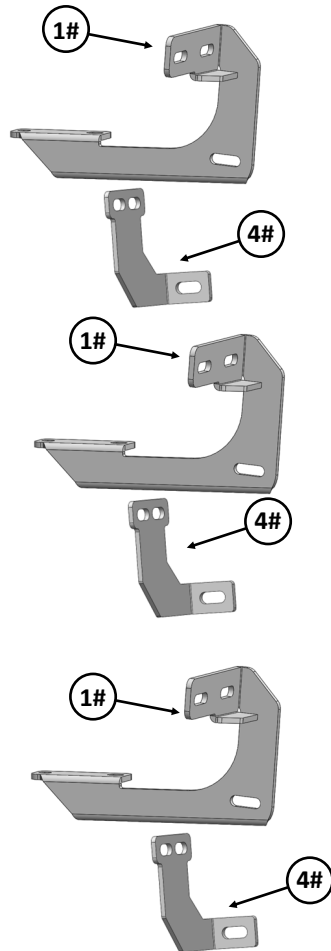
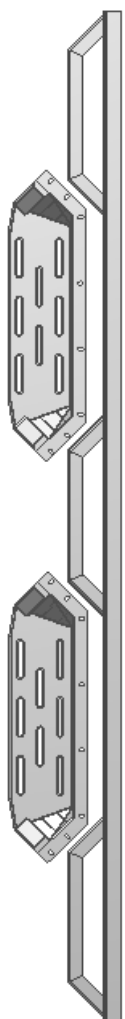

Customer Support: info@iarmorauto.com

iArmor®

Hardware Package					
Item	QTY	Description	Item	QTY	Description
1#	3	Driver Side Mounting Brackets	9#	12	M8 Lock Washers
2#	3	Passenger Side Mounting Brackets	10#	6	M8X1.25 Nylon Lock Nuts
3#	3	Passenger Side Support Brackets	11#	6	M8X1.25 Hex Nuts
4#	3	Driver Side Support Brackets	12#	12	M6X1-25 Hex Bolt
5#	6	M8 Bolt/Nut Plates	13#	68	M6 Large Flat Washers
6#	6	M8 Plastic Washers	14#	56	M6X1 Nylon Lock Nuts
7#	18	M8X1.25-30 Hex Bolts	15#	44	M6X1-20 T-Bolts
8#	24	M8 Large Flat Washers			

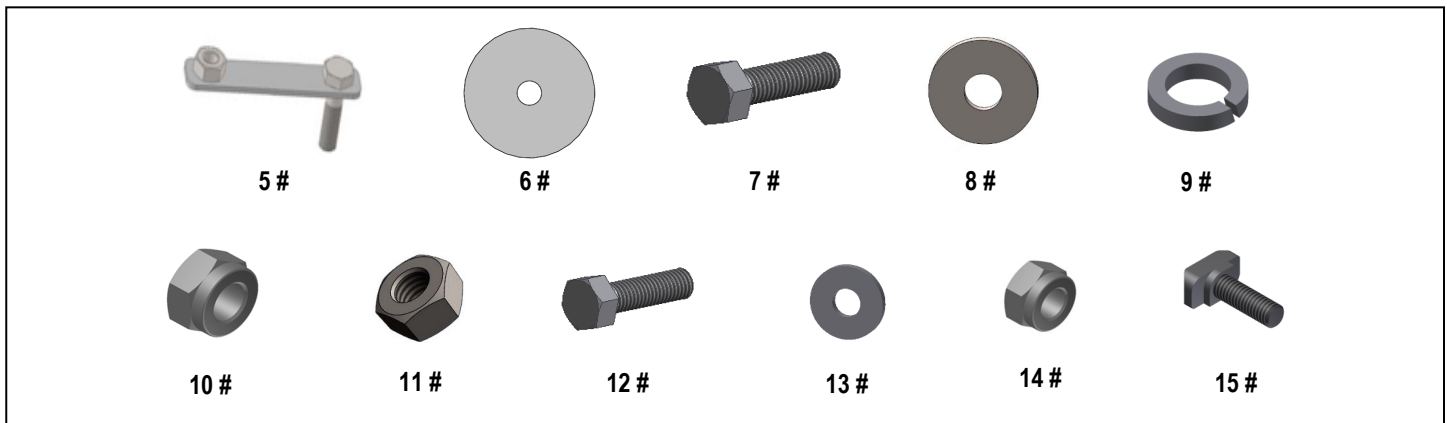

iArmor[®]

The instruction here is for your reference only. We strongly recommend the professional installer for best result. We are not responsible for any damage caused by the installation.

STEP 1

Install the Step Pads onto the step bars with (32) M6X1-20mm T-Bolts, (32) M6 Large Flat Washers and (32) M6X1 Nylon Lock Nuts.

IMPORTANT: Don't hit the step pad with any metal hammer within step pad installation, or the step pad will be damaged.

(8) M6X1-20mm T-Bolts
(8) M6 Large Flat Washers
(8) M6X1 Nylon Lock Nuts

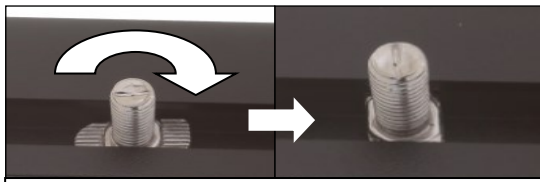

Note: Rotate 90° after inserting the T-Bolts into the Channel!!!

STEP 2

Starting installation from the driver side front of the vehicle, remove the sealing tape covering the factory holes on the inner side of body panel if equipped, (Fig 1).

Note: All Mounting Brackets and Supporting Brackets for Driver Side are the same.

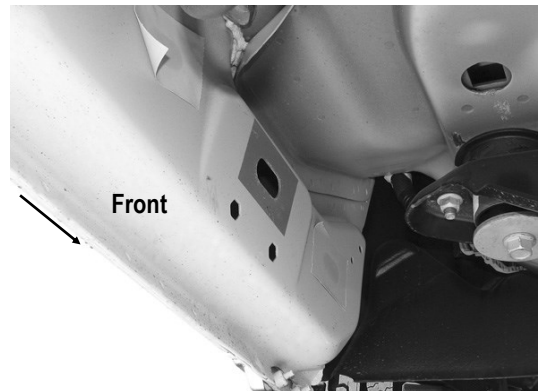

(Fig 1) Driver Side Front Mounting Location
(No factory holes on pinch weld on some trims)

STEP 3

Determine the correct procedure to attach (1) Driver Front Mounting Bracket for your model/year:

Models without factory threaded inserts in body panel:

- Partially thread (1) M8X1.25-30mm Hex Bolt into the threaded end of (1) M8 Bolt/Nut Plate, (Fig 2). Thread the hex bolt in until it is flush with the welded nut, (Fig 3). Use the M8 hex bolt as a handle and insert the Bolt/Nut Plate into the oval hole, (Fig 4). Feed the threaded bolt of the Bolt/Nut plate through one of the hex shaped factory holes. Thread (1) M8 Plastic Washer onto the threaded end and down tight against the body panel, (Fig 5). Then remove the M8 Hex Bolt.

NOTE: The Plastic washer is designed to keep the Bolt/Nut Plate from falling into the body panel and to aid in bracket installation.

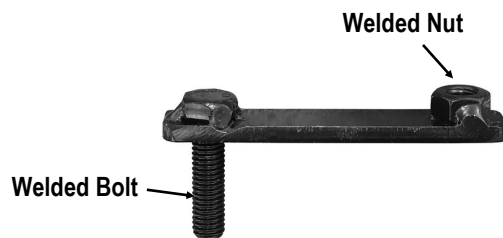

(Fig 2) M8 Bolt/Nut Plate (NOTE: M8 Bolt/Nut Plate is not required on models with threaded inserts on body panel)

iArmor®

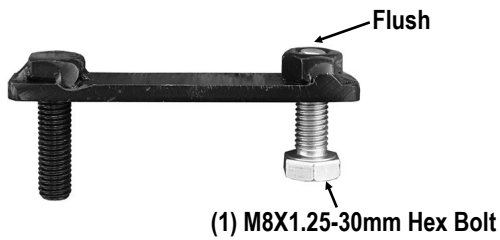

(Fig 3) Thread (1) M8X1.25-30mm Hex Bolt into the nut on the plate. Stop when bolt reaches end of nut as pictured

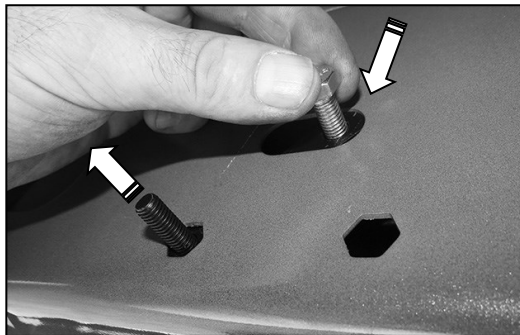

(Fig 4) Use the loose Hex Bolt as a handle. Insert the Bolt/Nut Plate into the oval hole and feed the threaded end out either factory hex shaped hole.

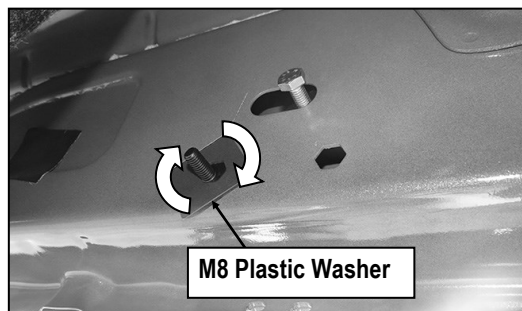

(Fig 5) Thread Plastic Washer onto the bolt to hold the Bolt/Nut Plate in position

Note: Do Not Remove The Hex Bolt Until The M8 Plastic Washer Has Been Threaded Onto the Welded Bolt.

b. Select (1) Driver Front Mounting Bracket. Attach the mounting bracket to the welded bolt end of the M8 Bolt/Nut Plate with (1) M8 Large Flat Washer, (1) M8 Lock Washer and (1) M8X1.25 Hex Nut, (Fig 6A). Do not fully tighten at this time.

Hold the welded bolt on the M8 Bolt/Nut Plate and rotate the Bolt/Nut Plate until the welded nut lines up with the remaining hex hole on the body panel.

(1) M8 Large Flat Washer
(1) M8 Lock Washer
(1) M8X1.25 Hex Nut

Rotate M8 Bolt/Nut Plate To Line Up the Welded Nut With the Hex Hole on Body Panel (See Arrow)

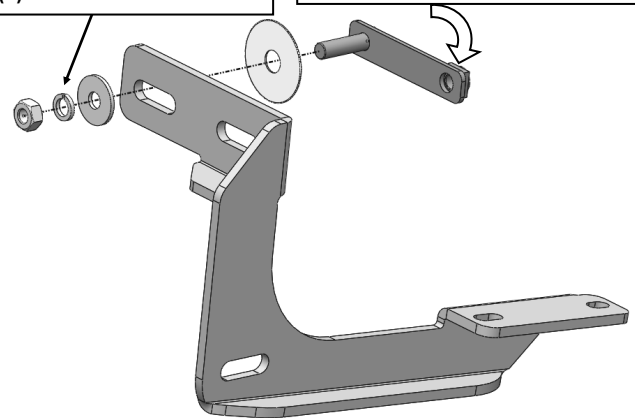

(Fig 6A) Attach Driver Front Mounting Bracket To the Welded Bolt on M8 Bolt/Nut Plate

c. Secure the Driver Front Mounting Bracket to the welded nut on the M8 Bolt/Nut Plate with (1) M8X1.25-30mm Hex Bolt, (1) M8 Lock Washer and (1) M8 Large Flat Washer, (Fig 6B). Do not fully tighten hardware at this time.

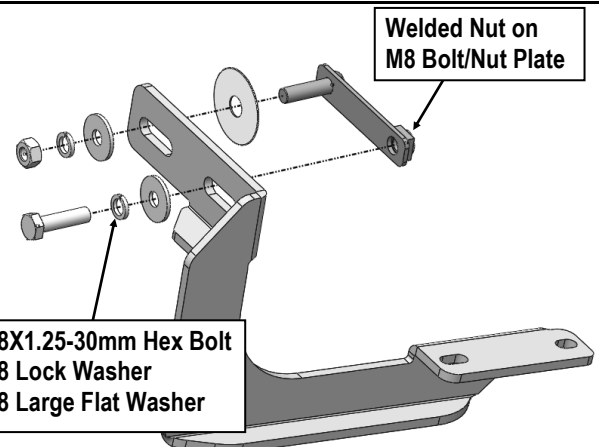

(Fig 6B) Secure Driver Front Mounting Bracket To the Welded Nut on M8 Bolt/Nut Plate

iArmor®

Models with factory threaded inserts:

Attach Driver Front Mounting Bracket to the threaded inserts with (2) M8X1.25-30mm Hex Bolts, (2) M8 Lock Washers and (2) M8 Large Flat Washers, (Figs 7 & 8). Do not fully tighten hardware at this time.

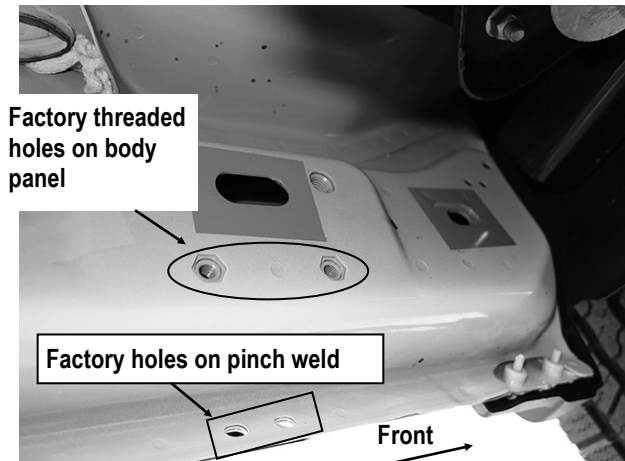

(Fig 7) Driver Side Front Mounting Location (example of models with factory threaded inserts)

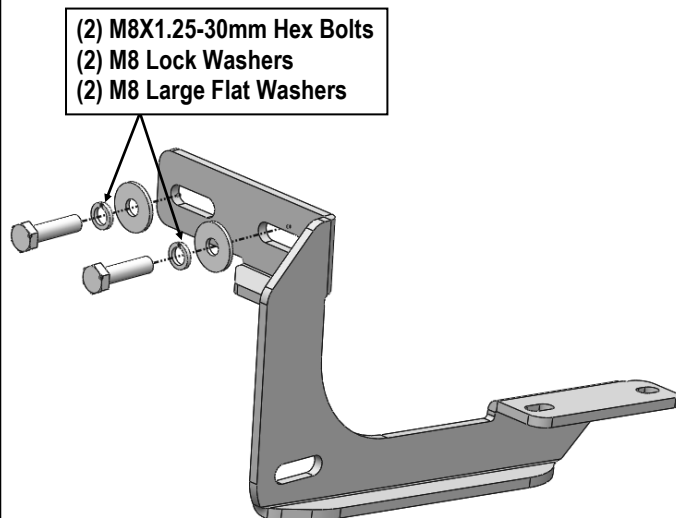

(Fig 8) Driver Front Mounting Bracket Installation (For Models With Factory Threaded Inserts. Bolt Plate Is Not Required Here)

STEP 4

Attach the Driver Front Support Bracket to the Driver Front Mounting Bracket with (1)M8X1.25-30 Hex Bolt, (2) M8 Large Flat Washers and (1) M8X1.25 Nylon Lock Nut, (Fig 9).

Rotate and attach the support bracket to the back of the pinch weld. Line up the slots in the top of the Support Bracket with the (2) factory holes on the pinch weld (Fig 7). Secure the Bracket to the back of the pinch weld with (2) M6X1-25 Hex Bolts, (4) M6 Flat Washers and (2) M6X1 Nylon Lock Nuts, (Fig 10). Do not fully tighten hardware at this time.

IMPORTANT: Some models are not equipped with factory holes and will require drilling through the pinch weld to attach the Support Bracket. Do not drill through pinch weld at this time, (Refer to Step 7).

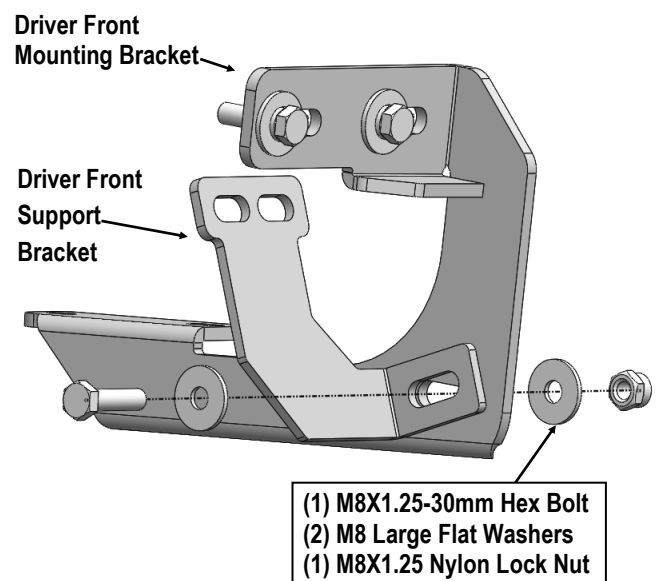

(Fig 9) Attach Driver Front Support Bracket to the Driver Front Mounting Bracket

iArmor[®]

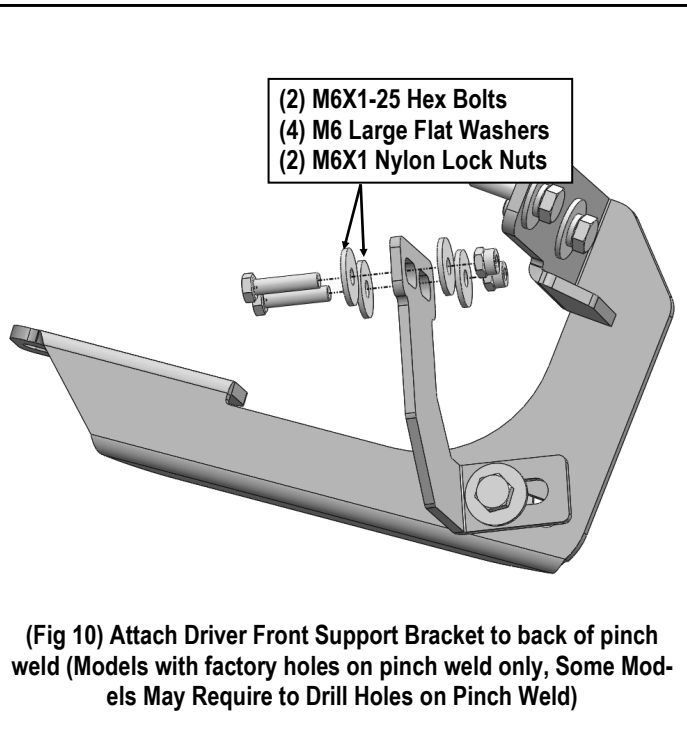

(Fig 10) Attach Driver Front Support Bracket to back of pinch weld (Models with factory holes on pinch weld only, Some Models May Require to Drill Holes on Pinch Weld)

STEP 5

Move along the side of the body panel to the center and rear mounting locations, (Figs 11-12). Repeat Steps 2-4 to install the driver side center & rear Brackets, (Fig 14).

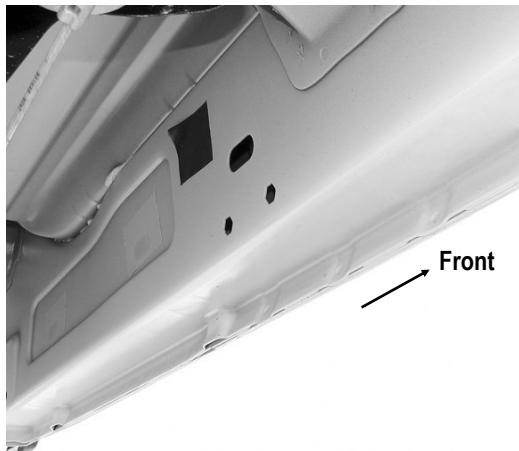

(Fig 11) Driver Side Center Mounting location



(Fig 12) Driver Side Rear Mounting Location

STEP 6

Once all (3) Brackets have been installed, attach the Assembled Driver Side Step Bar to the Mounting Brackets with (6) M6X1-20 T-Bolts, (6) M6 Flat Washers and (6) M6X1 Nylon Lock Nuts (Fig 13). Do not fully tighten hardware at this time.

STEP 7

Properly level and adjust the Step Bar and fully tighten all hardware.

Models requiring drilling for driver side Support Brackets:

- Make sure the Step Bar is level to the vehicle. Adjust and tighten all mounting hardware.
- Line up the slots on the Support Brackets with the back of the pinch weld. Mark the location of the slots onto the pinch weld.
- Drill (2) 1/4" holes through the pinch weld for each Support Bracket. **IMPORTANT:** Do not drill too close to the bottom edge of the pinch weld. Adjust the Brackets as necessary to move the slots up the body panel away from the edge. Drill the holes toward the outside of the marked slots.
- Attach each Support Brackets to the pinch weld with (2) M6X1-25 Hex Bolts, (4) M6 Large Flat Washers and (2) M6X1 Nylon Lock Nuts, (Fig 10). Check for level then fully tighten all hardware.

iArmor®

STEP 8

Move to the passenger side of the vehicle. Repeat **Steps 2-7** to install the passenger side step bar.

NOTE: All Mounting Brackets and Support Brackets for passenger side are the same.

Attention

Do periodic inspections to the installation to make sure that all hardware is secure and tight.

In order to protect your bars/boards, please use mild soap/non-abrasive products for cleaning only.

(Fig 13) Driver Side Step Bar Installed

- (6) M6X1-20 T-Bolts
- (6) M6 Large Flat Washers
- (6) M6X1 Nylon Lock Nuts

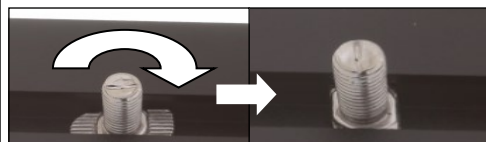
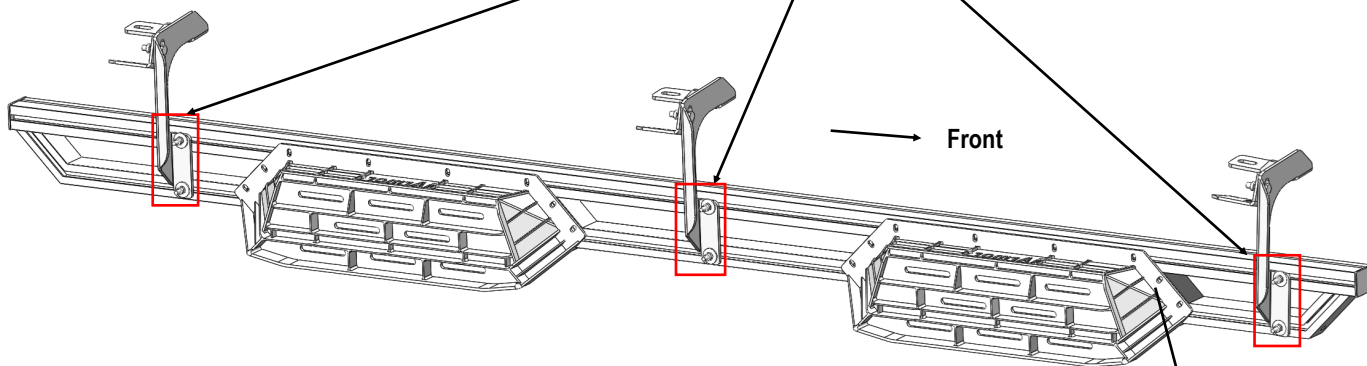

Warning: Install the T-bolt on the step bar and rotate it to 90 degrees!!!

