

# iArmor®

## IARMOR EDGE™

PART#: IA-N159

### BEFORE INSTALLATION

REMOVE CONTENTS FROM BOX. VERIFY ALL PARTS ARE PRESENT. READ INSTRUCTIONS CAREFULLY BEFORE STARTING INSTALLATION. ASSISTANCE IS RECOMMENDED. THANK YOU FOR CHOOSING OUR PRODUCT!

\*DRILLING NOT REQUIRED

\*TRIMMING NOT REQUIRED

### Torque Value

Fastener Size	Tightening Torque (ft-lbs)	Required
6mm	6-7	√
8mm	16-18	√
10mm	31-32	X
12mm	56-58	X
14mm	92-94	X

### PART LIST

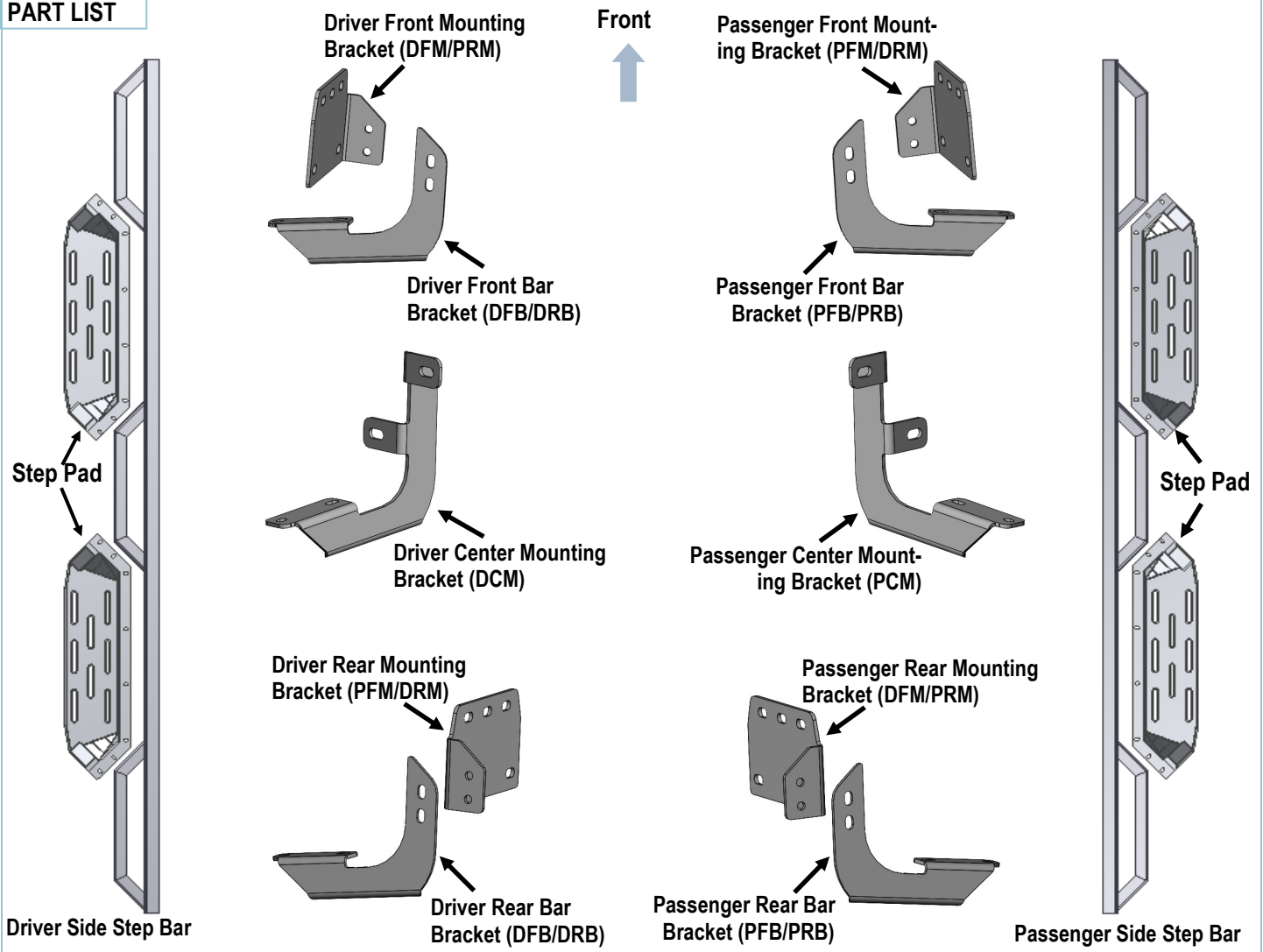

Customer Support: [info@iarmorauto.com](mailto:info@iarmorauto.com)

# iArmor®



M8X1.25-20 Hex Flange Bolt



M8X1.25 Hex Flange Nut



M8 Flat Washer



M8X1.25 Nylon Lock Nut



M6X1-20 T-Bolt



M6 Large Flat Washer



M6X1 Nylon Lock Nut

The instruction here is for your reference only. We strongly recommend the professional installer for best result. We are not responsible for any damage caused by the installation.

## STEP 1

Install the Step Pads onto the step bars with (32) M6X1-20mm T-Bolts, (32) M6 Large Flat Washers and (32) M6X1 Nylon Lock Nuts.

**IMPORTANT:** Don't hit the step pad by any metal hammer within step pad installation, or the step pad will be damaged.

(8) M6X1-20 T-Bolts  
(8) M6 Flat Washers  
(8) M6 Nylon Lock Nuts

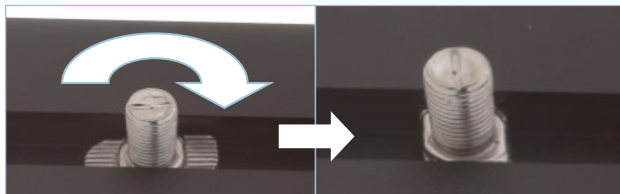

**Note: Rotate 90° after inserting the T-Bolts into the Channel!!!**

## STEP 2

Starting on the passenger side front of the vehicle, locate the front (3) factory studs along the inner side of the body panel, (Fig 1). **NOTE:** Use a wire brush or die to remove paint buildup from the threaded studs.

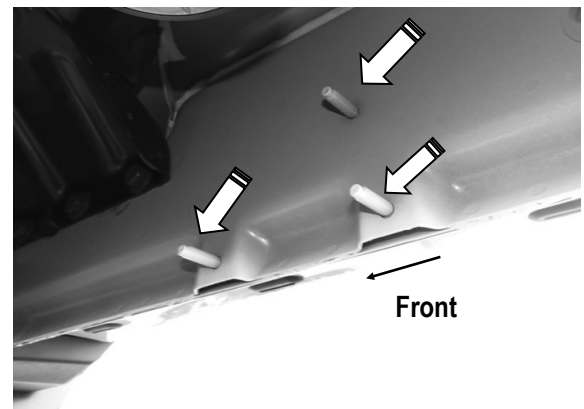

(Fig 1) Passenger Side Front Mounting Location

## STEP 3

Assemble the Passenger Front Mounting Bracket (PFM/DRM) and Passenger Front Bar Bracket (PFB/PRB) with (2) M8X1.25 -20 Hex Flange Bolts and (2) M8X1.25 Hex Flange Nuts, (Fig 2). Do not fully tighten hardware at this time.

# iArmor®

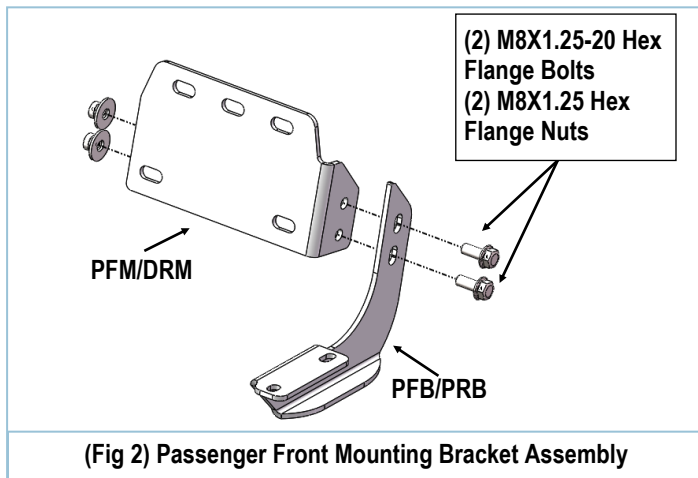

## STEP 4

Attach the assembled Passenger Front Mounting Bracket to the vehicle using the included (3) M8 Flat Washers, (3) M8X1.25 Nylon Lock Nuts. (Fig 3). Do not tighten hardware at this time.

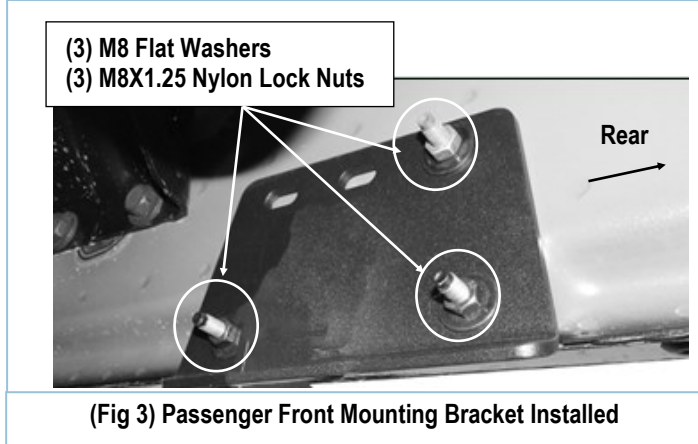

## STEP 5

Repeat **Steps 2– 4** to install the passenger side center and rear mounting brackets, (Figs 4 & 5). Do not fully tighten hardware at this time.

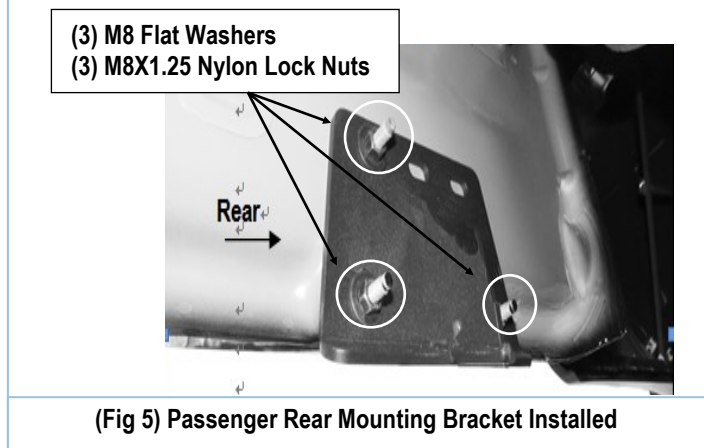
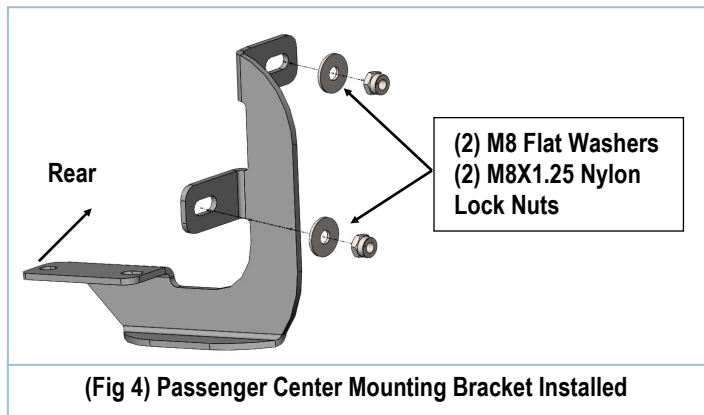

## STEP 6

Once all (3) brackets have been fully installed, attach the assembled passenger step bar onto the brackets with (6) M6X1-20 T-Bolts, (6) M6 Large Flat Washers and (6) M6X1 Nylon Lock Nuts, (Fig 6). Do not fully tighten hardware at this time.

## STEP 7

Properly level and adjust the Step Bar and fully tighten all hardware.

# iArmor®

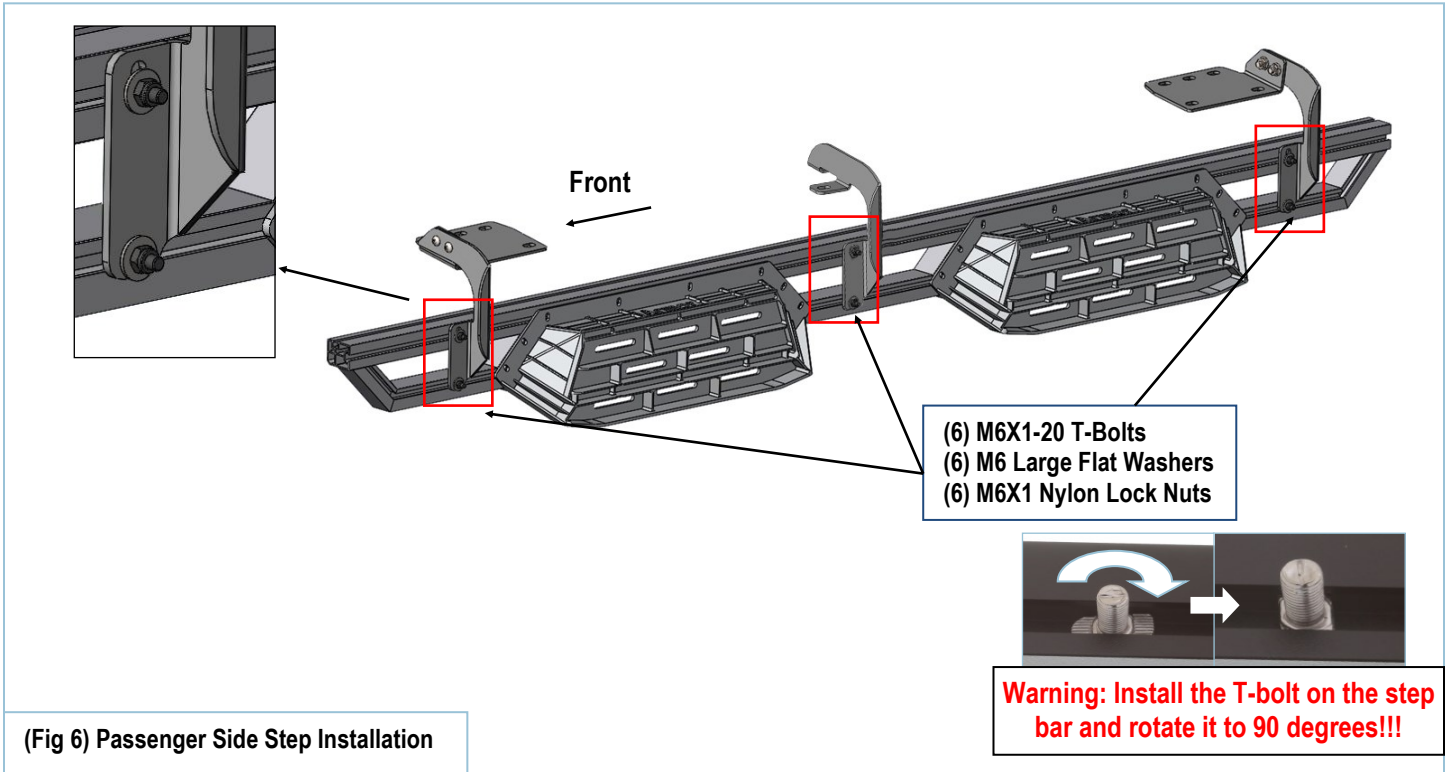

(Fig 6) Passenger Side Step Installation

## STEP 8

Move to the driver side of the vehicle. Repeat **Steps 2-7** to install the driver side step bar.

### Attention

Do periodic inspections to the installation to make sure that all hardware is secure and tight.

In order to protect your bars/boards, please use only mild soap/non-abrasive products for cleaning.