

iArmor®

IARMOR EDGE™

PART#: IA-W022

BEFORE INSTALLATION

REMOVE CONTENTS FROM BOX. VERIFY ALL PARTS ARE PRESENT. READ INSTRUCTIONS CAREFULLY BEFORE STARTING INSTALLATION. ASSISTANCE IS RECOMMENDED. THANK YOU FOR CHOOSING OUR PRODUCT!

*ROCKER PANEL MOUNT

*DRILLING / TRIMMING NOT REQUIRED

Fastener Size	Tightening Torque (ft-lbs)	Required
6mm	6-7	X
8mm	16-18	√
10mm	31-32	√
12mm	56-58	X
14mm	92-94	X

Driver

Front

Passenger

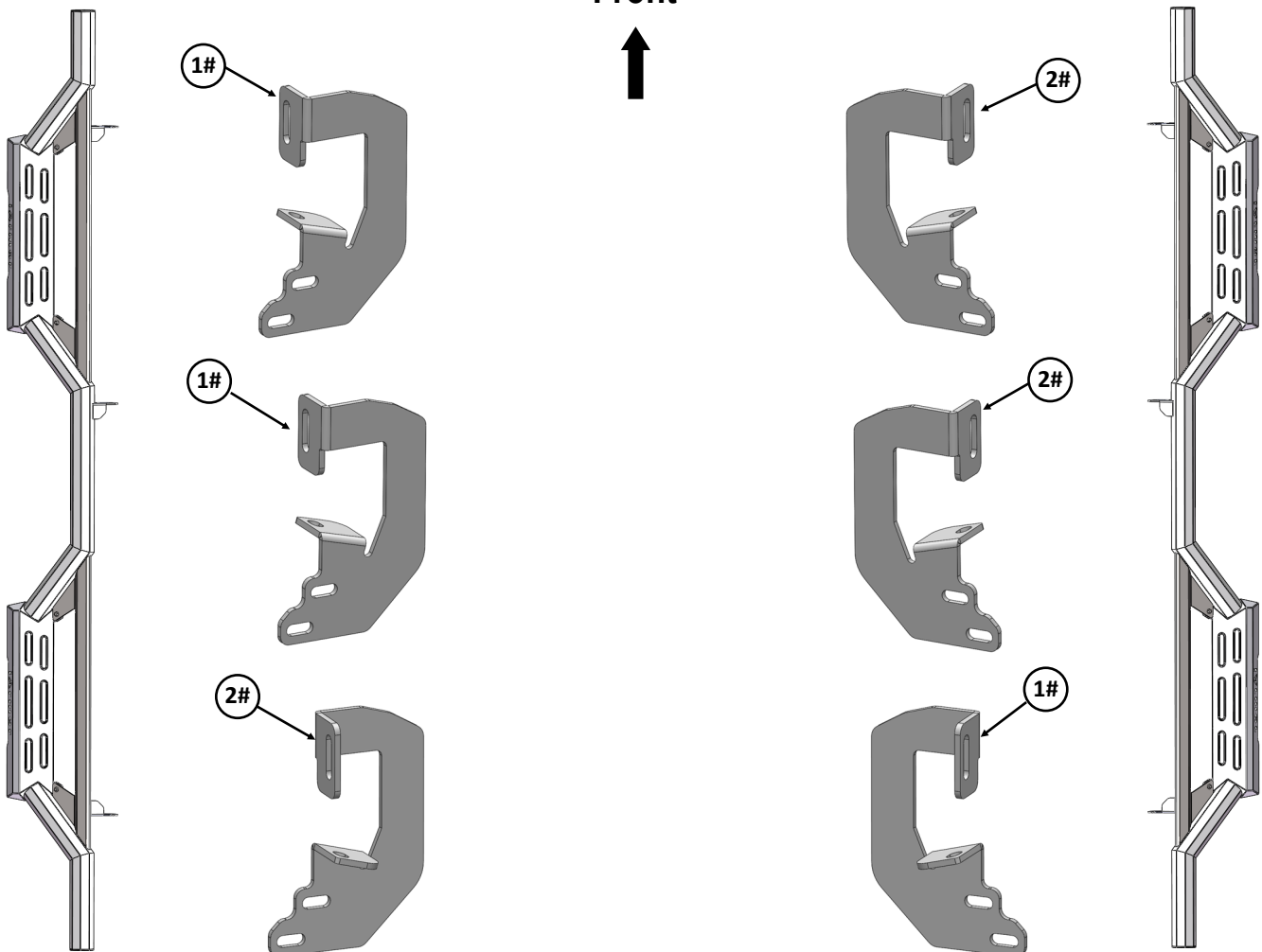

Customer Support: info@iarmorauto.com

iArmor[®]

Hardware Package (For Brackets & Step Bars Installation)

Item	QTY	Description	Item	QTY	Description
1#	3	Driver Front/Center/Passenger Rear Mounting Brackets	6#	12	M8X1.25 Hex Nuts
2#	3	Passenger Front/Center/Driver Rear Mounting Brackets	7#	12	M10X1.5-25 Hex Bolts
3#	12	M8X1.25-20 Hex Bolts	8#	24	M10 Flat Washers
4#	18	M8 Large Flat Washers	9#	12	M10X1.5 Nylon Lock Nuts
5#	12	M8 Lock Washers			



iArmor®

The instruction here is for your reference only. We strongly recommend the professional installer for best result. We are not responsible for any damage caused by the installation.

STEP 1

Start installation from the driver side front of the vehicle. Locate the factory threaded hole or stud located on the inner body panel, and (1) hole on the pinch weld, (**Fig 1**). Remove the plastic plug or any insulation on the side panel to locate the threaded holes if equipped.

NOTE: It will be helpful for identifying the mounting holes to hold up a mounting bracket in place.

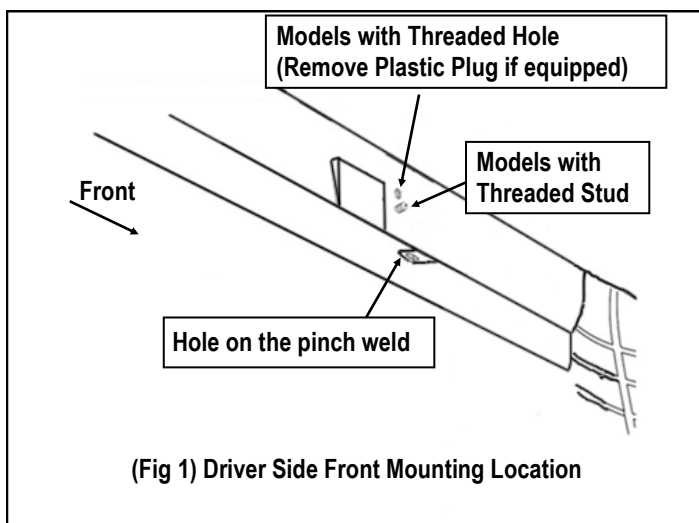

(Fig 1) Driver Side Front Mounting Location

STEP 2

Select (1) Driver Front Mounting Bracket. Install the Bracket as shown in (**Fig 2**). Do not fully tighten hardware at this time.

Note: Driver Front / Center Mounting Brackets and Passenger Rear Mounting Bracket are the same.

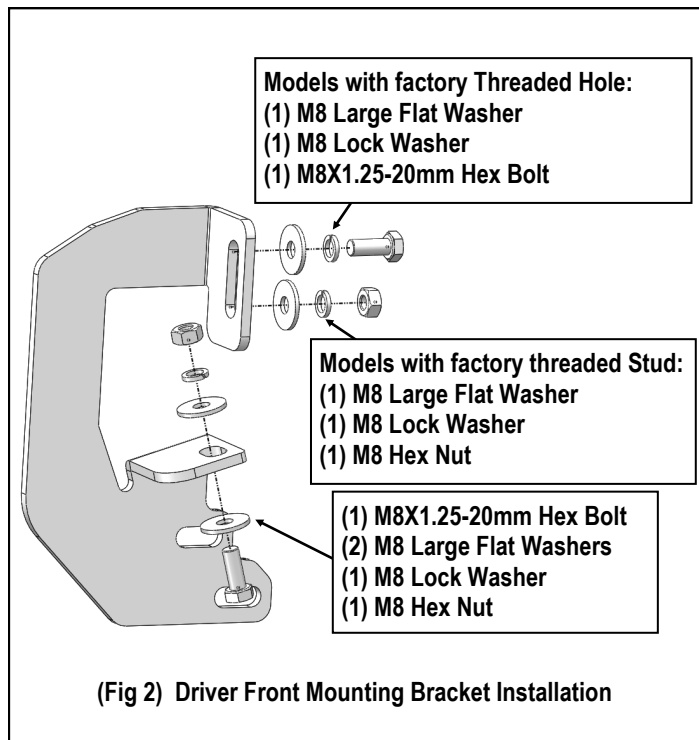

(Fig 2) Driver Front Mounting Bracket Installation

STEP 3

Move to the driver side center & rear mounting locations of the vehicle. Repeat **Step 2** to install the Driver Center & Rear Mounting Bracket. Do not fully tighten hardware at this time.

STEP 4

Once all (3) Driver Side Mounting Brackets have been installed, attach the Driver Side Step Bar to the Mounting Brackets with (6) M10X1.5-25 Hex Bolts, (12) M10 Flat Washers and (6) M10X1.5 Nylon Lock Nuts, (**Fig 3**).

Properly level and adjust the Step Bar and fully tighten all hardware.

STEP 5

Move to the other side of the vehicle. Repeat **Steps 1-4** to install the other side step bar.

iArmor[®]

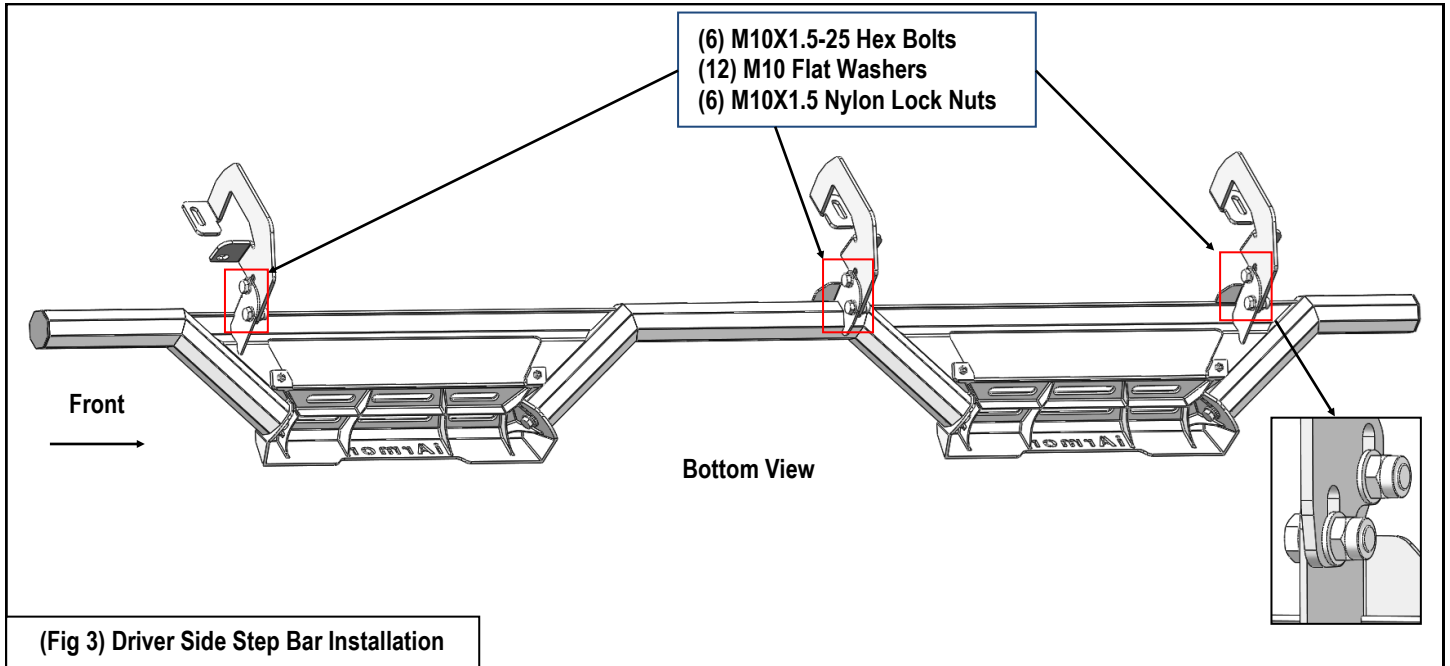

Attention

Do periodic inspections to the installation to make sure that all hardware is secure and tight.
In order to protect your bars/boards, please use mild soap/non-abrasive products for cleaning only.