

iArmor®

IARMOR EDGE™

PART#: IA-W171

BEFORE INSTALLATION

REMOVE CONTENTS FROM BOX. VERIFY ALL PARTS ARE PRESENT. READ INSTRUCTIONS CAREFULLY BEFORE STARTING INSTALLATION. ASSISTANCE IS RECOMMENDED. THANK YOU FOR CHOOSING OUR PRODUCT!

*ROCKER PANEL MOUNT

*DRILLING/TRIMMING NOT REQUIRED

Torque Value

Fastener Size	Tightening Torque (ft-lbs)	Required
6mm	6-7	X
8mm	16-18	√
10mm	31-32	√
12mm	56-58	X
14mm	92-94	X

PART LIST

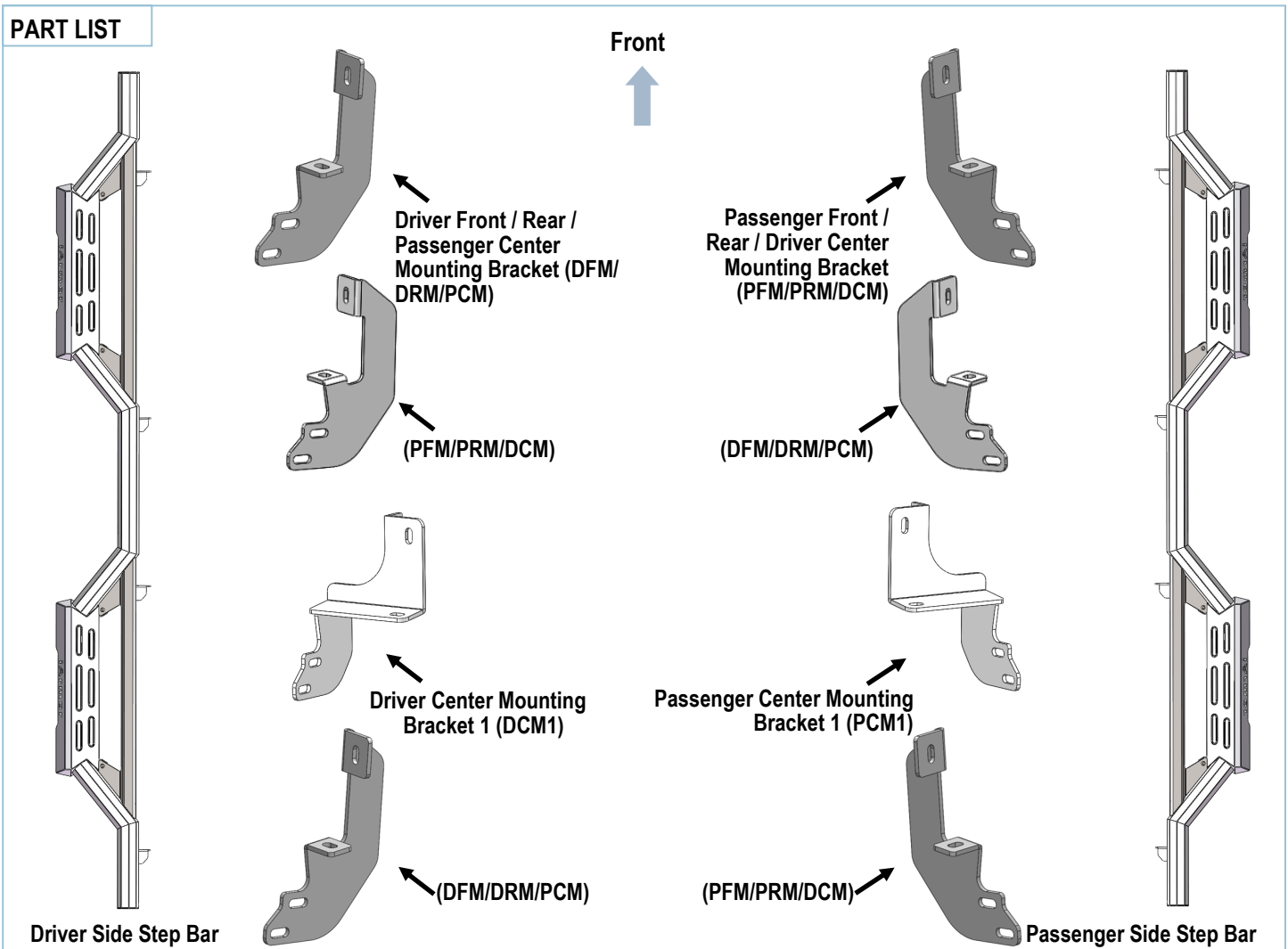

Customer Support: info@iarmorauto.com

iArmor[®]

Hardware Package (For Brackets & Step Bars Installation)

Item	QTY	Description	Item	QTY	Description
1#	16	M8X1.25-30 Hex Bolts	4#	16	M10X1.5-25 Hex Bolts
2#	16	M8 Large Flat Washers	5#	32	M10 Flat Washers
3#	16	M8 Lock Washers	6#	16	M10X1.5 Nylon Lock Nuts

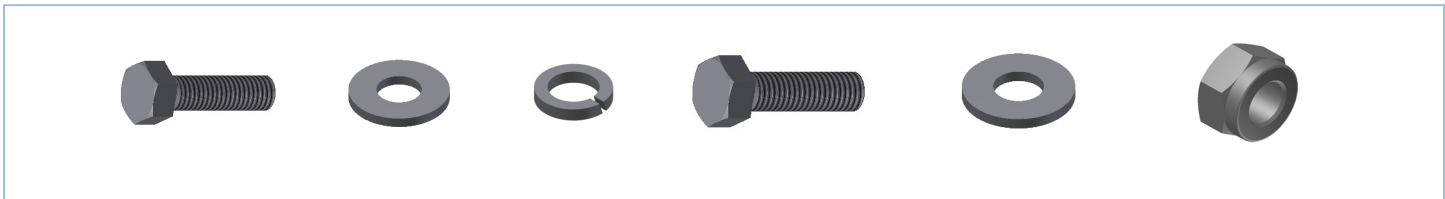

iArmor®

The instruction here is for your reference only. We strongly recommend the professional installer for best result. We are not responsible for any damage caused by the installation.

STEP 1

Start the installation under the driver side of the vehicle. Locate the 6 plugs along the bottom edge of the body panel. Mounting Brackets will bolt to the 1st, 3rd, 4th and 6th threaded mounting holes, **(Fig 1)**.

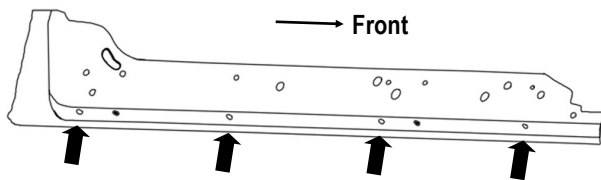

(Fig 1) Driver side Rocker Panel mounting locations (For Some Models)

STEP 2

Remove the plastic plugs from each mounting location if equipped. Hold up a Mounting Bracket in place to determine the mounting holes on the body panel, **(Figs 2 & 3)**.

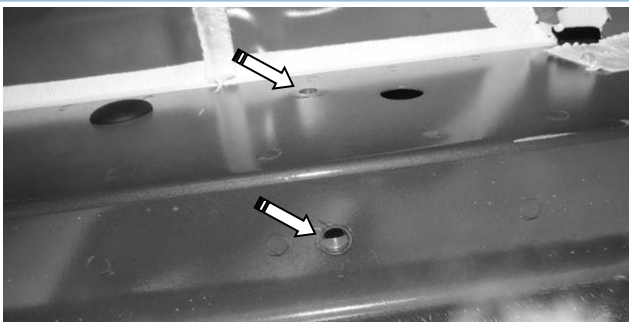

(Fig 3) Driver Side Front Mounting Location

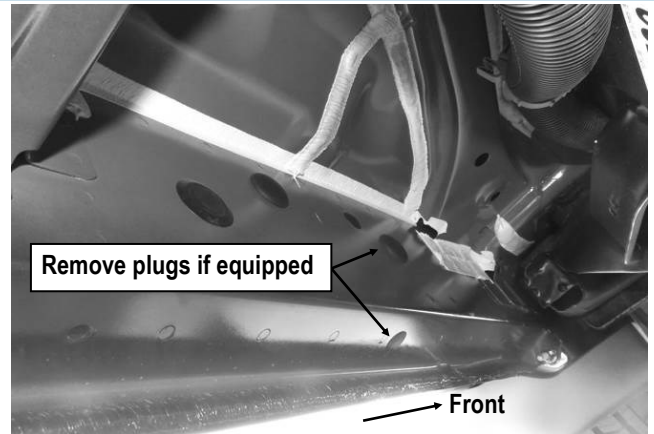

(Fig 2) Remove Plastic Plugs to Uncover Threaded Inserts

STEP 3

Select the Driver Front Mounting Bracket (**DFM**). Attach the Bracket to the factory threaded holes with (2) M8X1.25-30 Hex Bolts, (2) M8 Lock Washers and (2) M8 Large Flat Washers, **(Figs 4 & 5)**. Do not fully tighten hardware at this time.

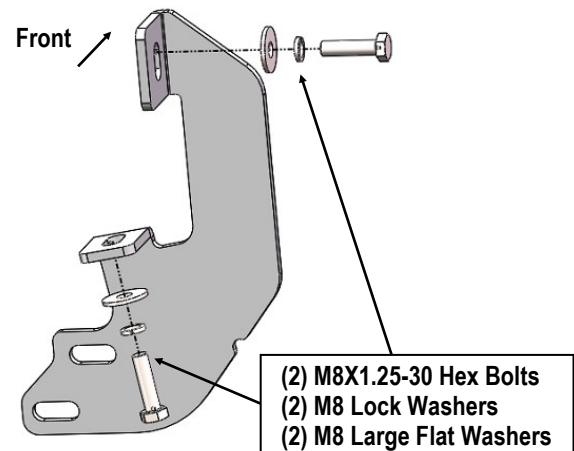

(Fig 4) Driver Front Mounting Bracket Installation

iArmor[®]

- (2) M8X1.25-30 Hex Bolts
- (2) M8 Lock Washers
- (2) M8 Large Flat Washers

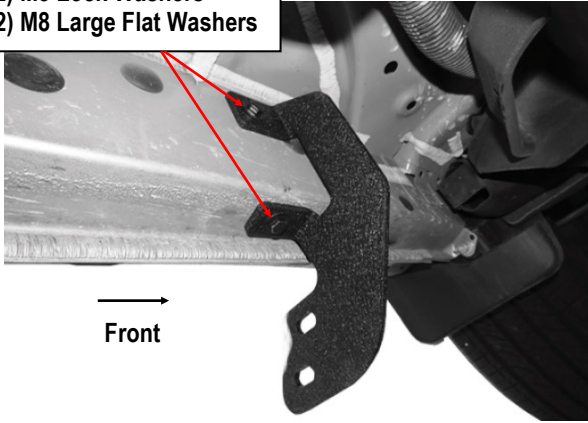

(Fig 5) Driver Front Mounting Bracket Installation

STEP 4

Move to the Driver Side 2nd, 3rd and rear Mounting Locations, (Figs 6-9). Repeat **Steps 1-3** to install the Driver Center & Center 1 & Rear Mounting Brackets. Do not fully tighten hardware at this time.

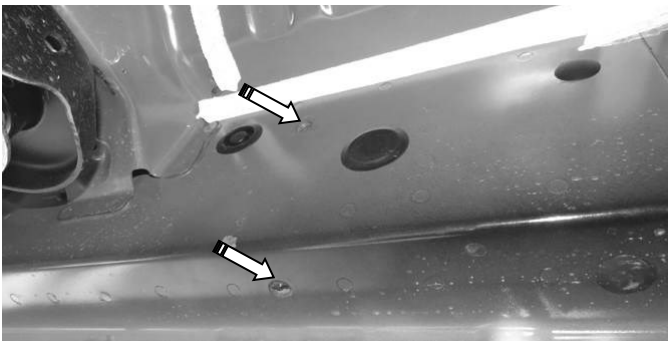

(Fig 6) Driver Side 2nd Mounting Location

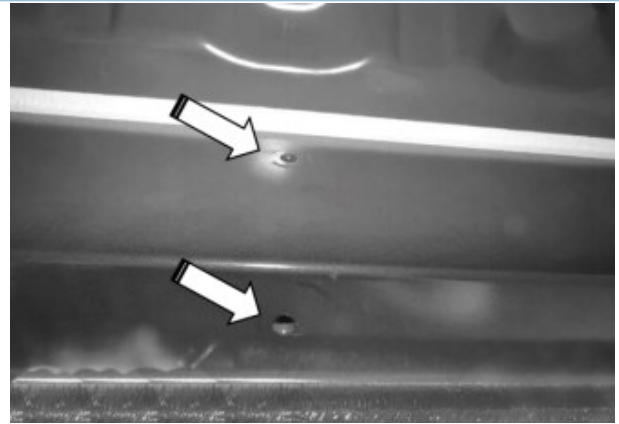

(Fig 7) Driver Side 3rd Mounting Location

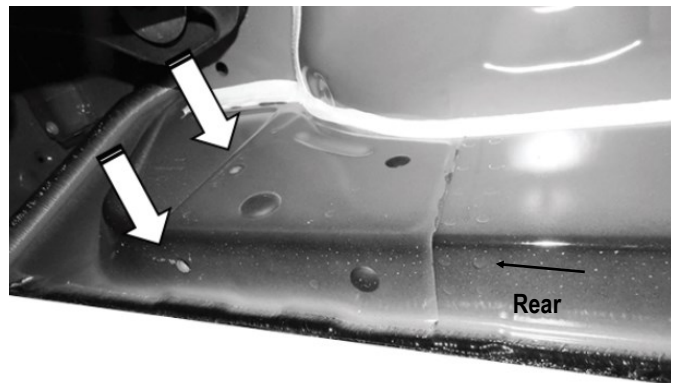

(Fig 8) Driver Side Rear Mounting Location

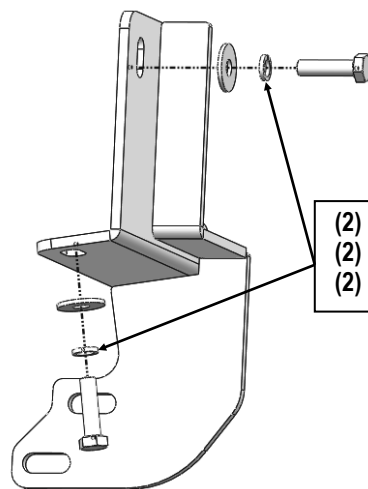

(Fig 9) Driver Center Mounting Bracket 1 (DCM1) Installation

iArmor[®]

STEP 5

Once all (4) Mounting Brackets have been installed, attach the Driver Side Step Bar to the Mounting Brackets with (8) M10X1.5-25 Hex Bolts, (16) M10 Flat Washers and (8) M10X1.5 Nylon Lock Nuts, (Fig 10). Do not fully tighten hardware at this time.

STEP 6

Properly level and adjust the Step Bar and fully tighten all hardware.

STEP 7

Move to the other side of the vehicle. Repeat **Steps 1-6** for the other Side Step Bar installation.

Attention

Do periodic inspections to the installation to make sure that all hardware is secure and tight.

In order to protect your bars/boards, please use mild soap/non-abrasive products for cleaning only.

