

# iArmor®

## IARMOR EDGE™

PART#: IA-W131

### BEFORE INSTALLATION

REMOVE CONTENTS FROM BOX. VERIFY ALL PARTS ARE PRESENT. READ INSTRUCTIONS CAREFULLY BEFORE STARTING INSTALLATION. ASSISTANCE IS RECOMMENDED. THANK YOU FOR CHOOSING OUR PRODUCT!

\*BODY FRAME MOUNT

\*DRILLING/TRIMMING NOT REQUIRED

### Torque Value

Fastener Size	Tightening Torque (ft-lbs)	Required
6mm	6-7	X
8mm	16-18	X
10mm	31-32	√
12mm	56-58	√
14mm	92-94	X

### PART LIST

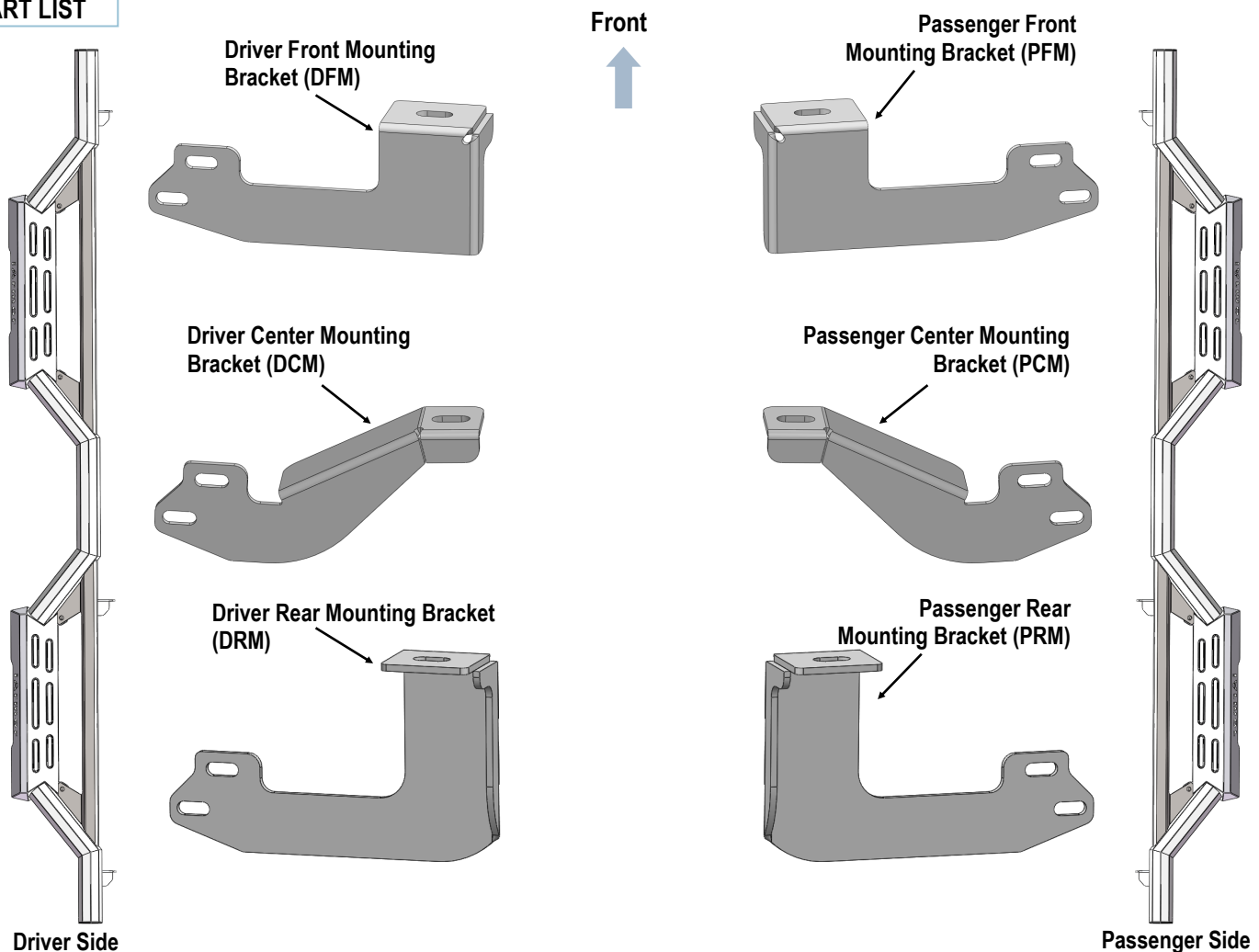

Customer Support: [info@iarmorauto.com](mailto:info@iarmorauto.com)

# iArmor<sup>®</sup>

## Hardware Package (For Brackets & Step Bars Installation)

Item	QTY	Description	Item	QTY	Description
1#	6	M12X1.75-120 Hex Bolts	4#	12	M10X1.5-25 Hex Bolts
2#	6	M12 Large Flat Washers	5#	24	M10 Flat Washers
3#	6	M12 Lock Washers	6#	12	M10X1.5 Nylon Lock Nuts



1#



2#



3#



4#



5#



6#

# iArmor®

The instruction here is for your reference only. We strongly recommend the professional installer for best result. We are not responsible for any damage caused by the installation.

## STEP 1

Start the installation from the Driver side of the vehicle. Remove the front and rear body mount hex bolts. Do not remove the rubber bushings, (Fig 1).

Factory Body Mount Bolt

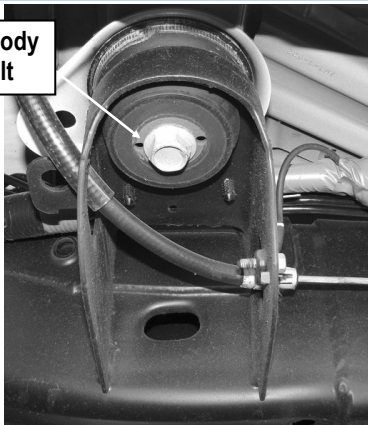

(Fig 1) Remove Factory Body Mount Bolt

## STEP 2

Hang the Driver Front & Center & Rear Mounting Brackets to the body mounts using the factory hex bolts, (Fig 2).

**NOTE: On some model years,** the factory bolts and flat washers can not be reinstalled due to Bracket interference. Replace the factory hex bolts and washers with the included M12X1.75-120mm Hex Bolts, M12 Lock Washers and M12 Large Flat Washers, (Fig 2). Do not fully tighten hardware at this time.

## STEP 3

Once all (3) Mounting Brackets have been installed, attach the Driver Side Bar to the assembled Bar Brackets with (6) M10X1.5-25 Hex Bolts, (12) M10 Flat Washers and (6) M10X1.5 Nylon Lock Nuts, (Fig 3). Do not fully tighten hardware at this time.

Properly level and adjust the Step Bar and fully tighten all hardware.

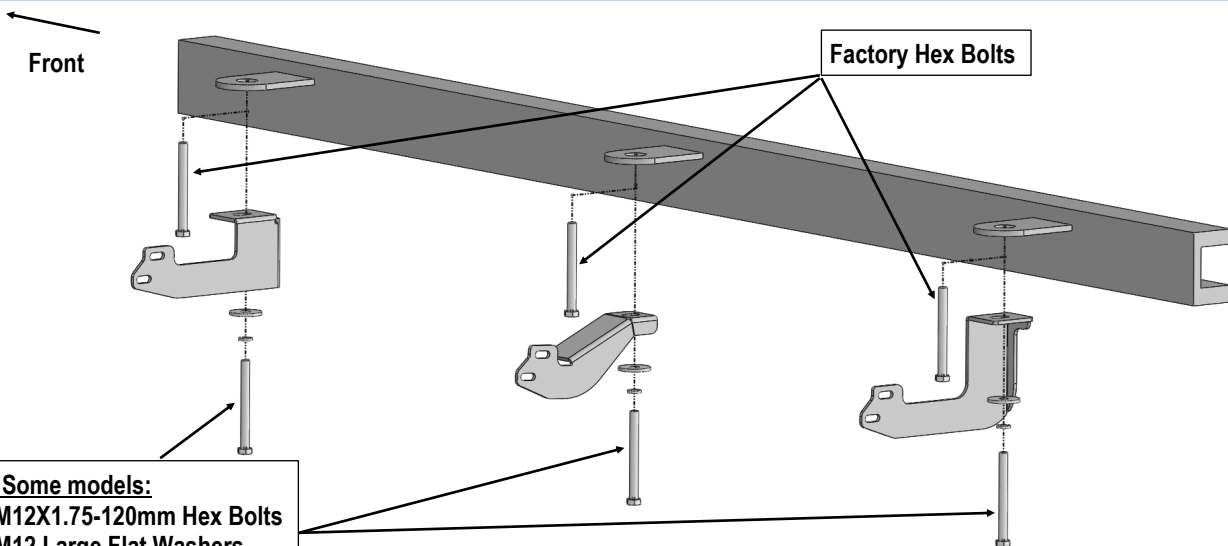

(Fig 2) Driver Side Mounting Brackets Installation

# iArmor<sup>®</sup>

## STEP 4

Move to the other side of the vehicle. Repeat **Steps 1-3** for the other side step bar installation.

### Attention

Do periodic inspections to the installation to make sure that all hardware is secure and tight.

In order to protect your bars/boards, please use mild soap/non-abrasive products for cleaning only.

