

iArmor[®]

iArmor[®] by APS

PART#: IA-S022

BEFORE INSTALLATION

REMOVE CONTENTS FROM BOX. VERIFY ALL PARTS ARE PRESENT. READ INSTRUCTIONS CAREFULLY BEFORE STARTING INSTALLATION. ASSISTANCE IS RECOMMENDED. THANK YOU FOR CHOOSING OUR PRODUCT!

*ROCKER PANEL MOUNT

*NO DRILLING/TRIMMING REQUIRED

Fastener Size	Tightening Torque (ft-lbs)	Required
6mm	6-7	X
8mm	16-18	√
10mm	31-32	X
12mm	56-58	X
14mm	92-94	X

Driver

Front

Passenger

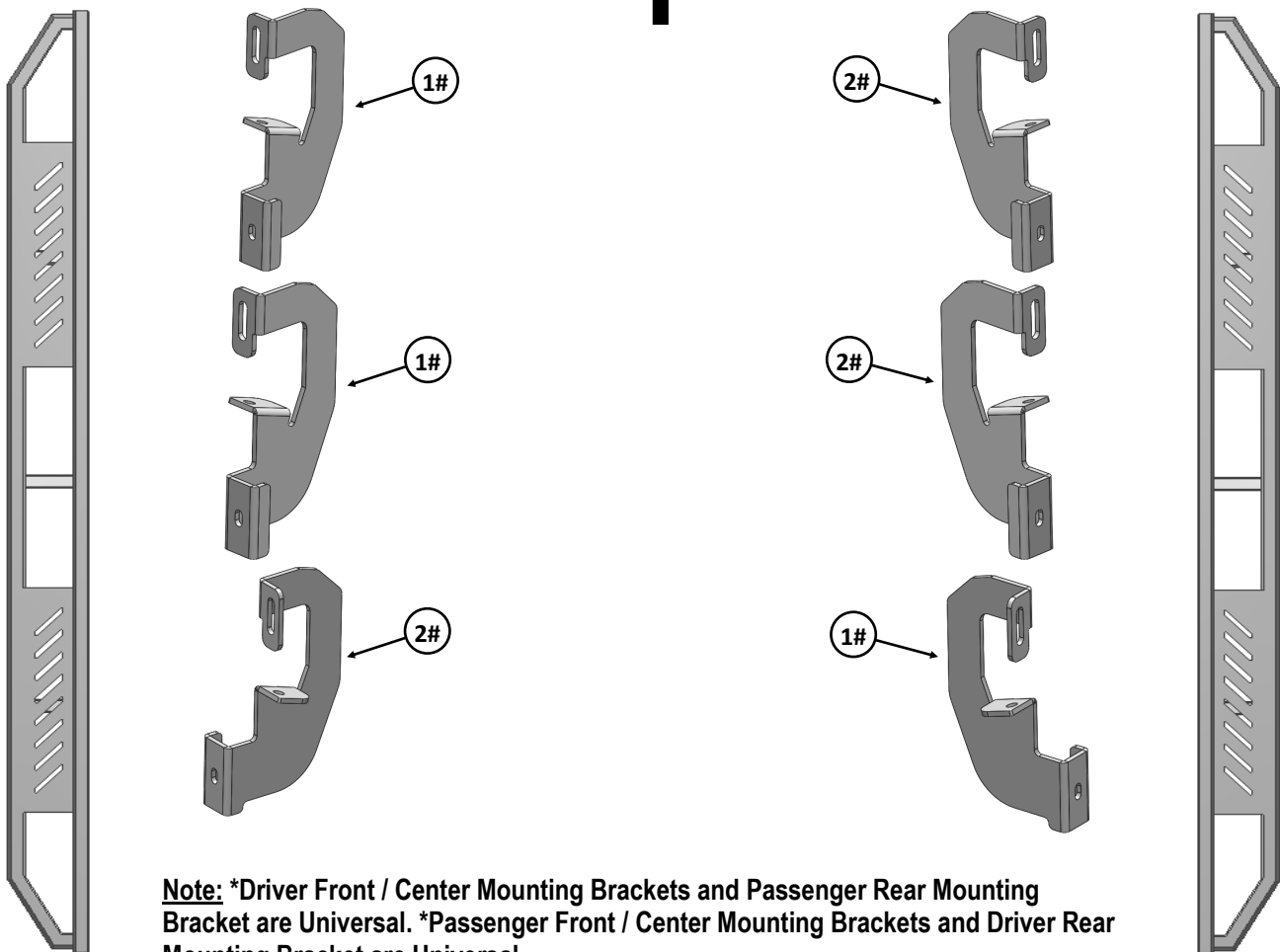

Note: *Driver Front / Center Mounting Brackets and Passenger Rear Mounting Bracket are Universal. *Passenger Front / Center Mounting Brackets and Driver Rear Mounting Bracket are Universal.

Customer Support: info@iarmorauto.com

iArmor®

Item	QTY	Description	Item	QTY	Description
1#	3	Driver Front & Center & Rear Mounting Brackets	6#	24	M8 Large Flat Washers
2#	3	Passenger Front & Center & Rear Mounting Brackets	7#	18	M8 Lock Washers
3#	6	U Brackets	8#	18	M8X1.25 Hex Nuts
4#	12	Spacers	9#	6	M8X1.25-55mm Carriage Bolts
5#	12	M8X1.25-20mm Hex Bolts			

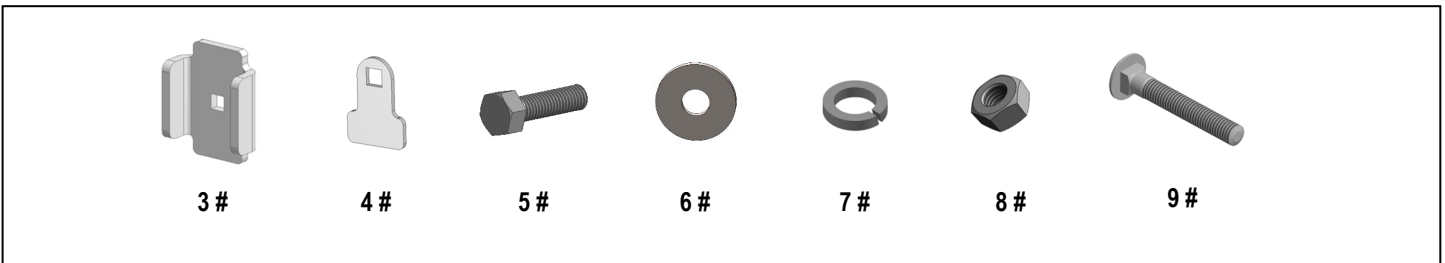

iArmor®

The instruction here is for your reference only. We strongly recommend the professional installer for best result. We are not responsible for any damage caused by the installation.

STEP 1

Start installation from the driver side front of the vehicle. Locate the factory threaded hole or stud located on the inner body panel, and (1) hole on the pinch weld, (**Fig 1**). Remove the plastic plug or any insulation on the side panel to locate the threaded holes if equipped.

NOTE: It will be helpful for identifying the mounting holes to hold up a mounting bracket in place.

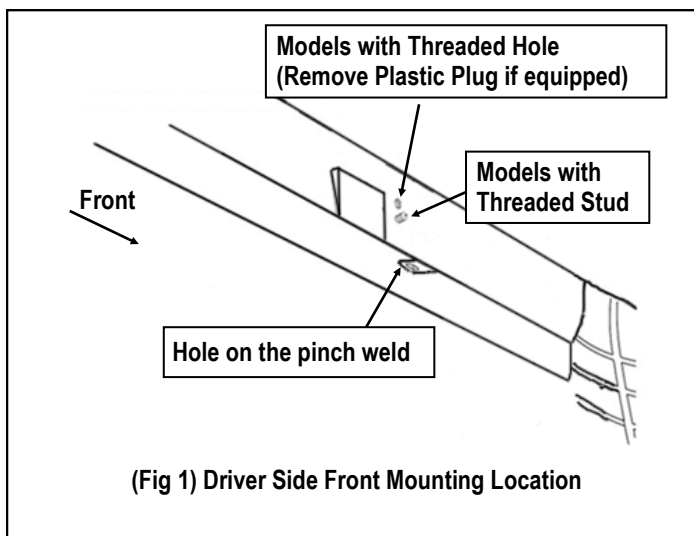

STEP 2

Select (1) Driver Front Mounting Bracket. Install the Bracket as shown in (**Fig 2**). Do not fully tighten hardware at this time.

Note: Driver Front / Center Mounting Brackets and Passenger Rear Mounting Bracket are the same.

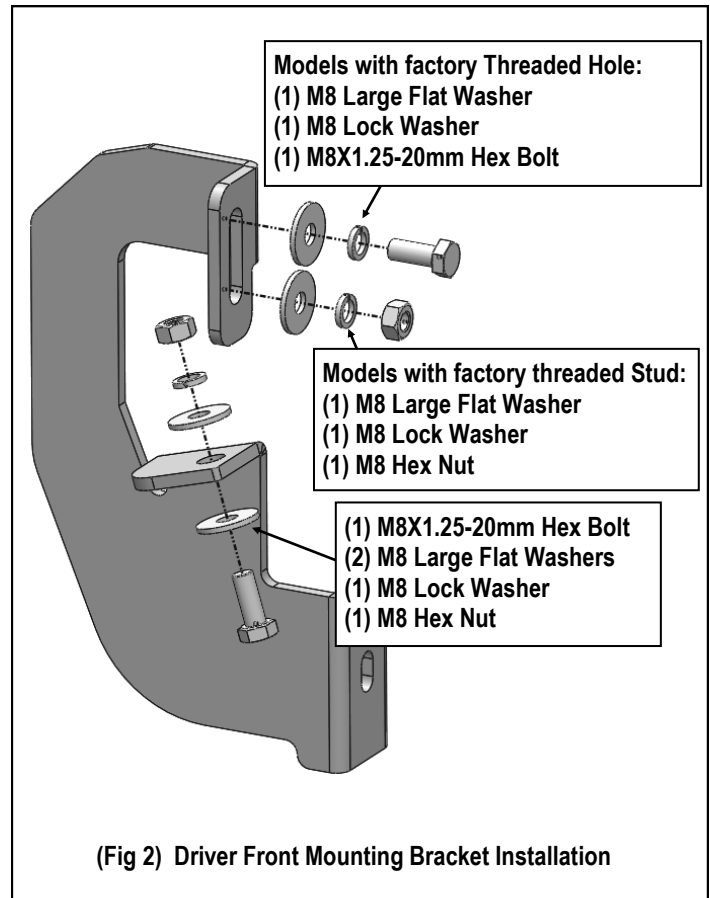

STEP 3

Move to the driver side center & rear mounting locations of the vehicle. Repeat **Step 2** to install the Driver Center & Rear Mounting Bracket. Do not fully tighten hardware at this time.

STEP 4

Once all (3) driver side mounting brackets are installed, select and attach the Driver Side Step Bar onto the Mounting Brackets with (3) U Brackets, (6) Spacers, (3) M8X1.25-55mm Carriage Bolts, (3) M8 Large Flat Washers, (3) M8 Lock Washers and (3) M8X1.25 Hex Nuts (**Fig 3**). Do not fully tighten hardware at this time.

STEP 5

Properly level and adjust the Step Bar and fully tighten all hardware.

iArmor[®]

STEP 6

Move to the other side of the vehicle. Repeat **Steps 1-5** to install the other side step bar.

Installation completed.

Attention

Do periodic inspections to the installation to make sure that all hardware is secure and tight.

In order to protect your bars/boards, please use mild soap/non-abrasive products for cleaning only.

NOTE: Torque all M8 X1.25-55mm Carriage Bolts to 16~18 lb-ft. Don't over tighten, or the aluminum square bars will be damaged by the brackets

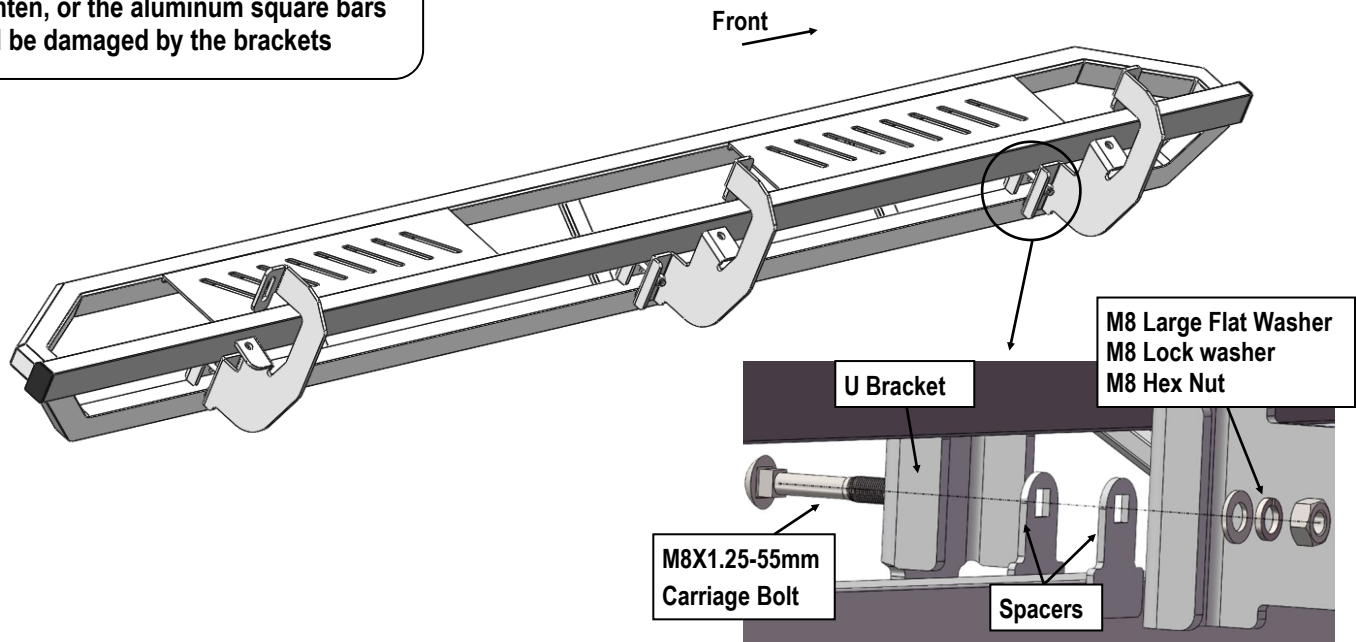

(Fig 3) Driver Side Step Bar Installed