

iArmor[®]

iArmor[®] by APS

PART#: IA-S296H

BEFORE INSTALLATION

REMOVE CONTENTS FROM BOX. VERIFY ALL PARTS ARE PRESENT. READ INSTRUCTIONS CAREFULLY BEFORE STARTING INSTALLATION. ASSISTANCE IS RECOMMENDED. THANK YOU FOR CHOOSING OUR PRODUCT!

*ROCKER PANEL MOUNT

*DRILLING NOT REQUIRED

Torque Value

Fastener Size	Tightening Torque (ft-lbs)	Required
6mm	6-7	X
8mm	16-18	√
10mm	31-32	X
12mm	56-58	X
14mm	92-94	X

PART LIST

Driver Side Step Bar

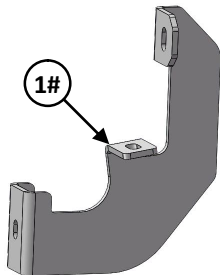
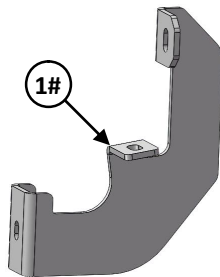
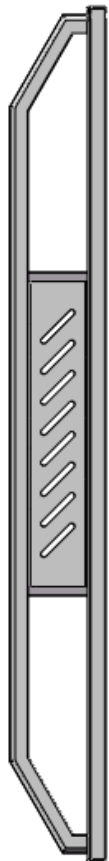

Front



Passenger Side Step Bar

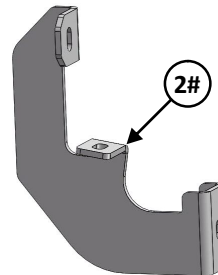
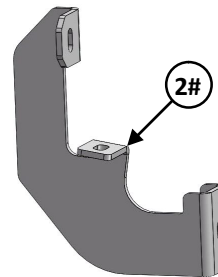

iArmor®

Hardware Package A (For Bracket Installation)					
Item	QTY	Description	Item	QTY	Description
1#	2	Driver Front / Rear Mounting Brackets	4#	8	M8X1.25-30mm Hex Bolts
2#	2	Passenger Front / Rear Mounting Brackets	5#	8	M8 Large Flat Washers
3#	4	U Brackets	6#	8	M8 Lock Washers

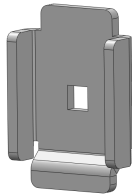

3 #



4 #



5 #



6 #

Hardware Package B (For Step Bar Installation)					
Item	QTY	Description	Item	QTY	Description
1#	4	M8X1.25-55mm Carriage Bolts	3#	4	M8 Lock Washers
2#	4	M8 Large Flat Washers	4#	4	M8 Hex Nuts

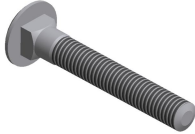

1 #



2#



3 #

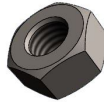

4 #

iArmor[®]

The instruction here is for your reference only. We strongly recommend the professional installer for best result. We are not responsible for any damage caused by the installation.

STEP 1

Start the installation under the Driver side of the vehicle. Locate the plastic plugs along the bottom edge of the body panel, (**Fig 1**). Mounting Brackets will be attached to the threaded mounting holes at the front and rear of the cab.

Remove the plastic plugs from the front mounting location. Directly above each threaded insert is a top mounting location on the side of the body panel.

NOTE:

- * Hold a Bracket up in place to help determine the correct mounting holes to be use along the body panel.
- * Thread an 8mm Hex Bolt into the threaded inserts to clear paint as required.

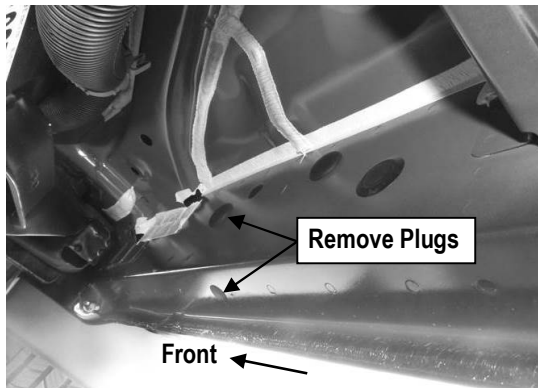

(Fig 1) Remove Plastic Plugs To Uncover Threaded Inserts

STEP 2

Start from the driver side front mounting location, (**Fig 2**). Bolt the Driver Front Mounting Bracket to the factory threaded holes with (2) M8X1.25-30mm Hex Bolts, (2) M8 Large Flat Washers and (2) M8 Lock Washers, (**Fig 3**). Do not fully tighten hardware at this time.

NOTE: All (2) Driver Side Mounting Brackets are universal.

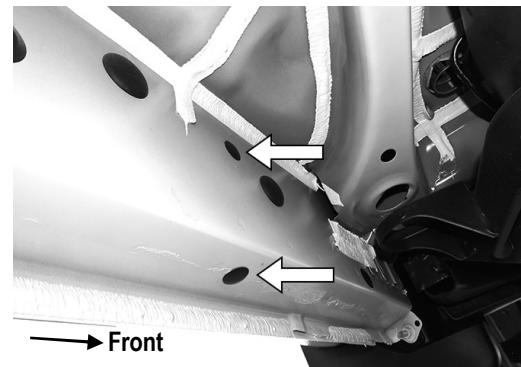

(Fig 2) Driver Side Front Mounting Location

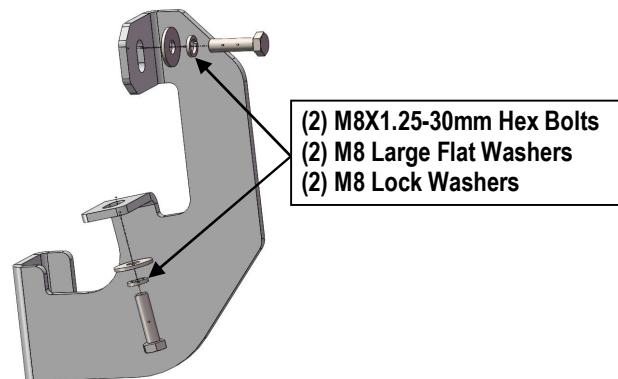

(Fig 3) Driver Front Mounting Bracket Installation

STEP 3

Move to driver side rear mounting location, (**Fig 4**). Repeat **Step 2** to bolt the Driver Rear Mounting Bracket to the factory threaded holes.

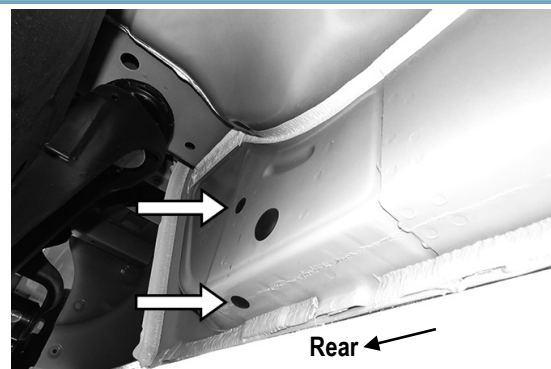

(Fig 4) Driver Side Rear Mounting Location

iArmor®

STEP 4

Once all (2) driver side mounting brackets are installed, select and attach the Driver Side Step Bar onto the Mounting Brackets with (2) U Brackets, (2) M8X1.25-55mm Carriage Bolts, (2) M8 Large Flat Washers, (2) M8 Lock Washers and (2) M8X1.25 Hex Nuts (**Fig 5**). Do not fully tighten hardware at this time.

STEP 5

Properly level and adjust the Step Bar and fully tighten all hardware.

STEP 6

Move to the passenger side of the vehicle. Repeat **Steps 1-5** to install the passenger side step bar.

Installation completed.

NOTE: Torque all M8 X1.25-55mm Carriage Bolts to 16~18 lb-ft. Don't over tighten, or the square bars will be damaged by the brackets

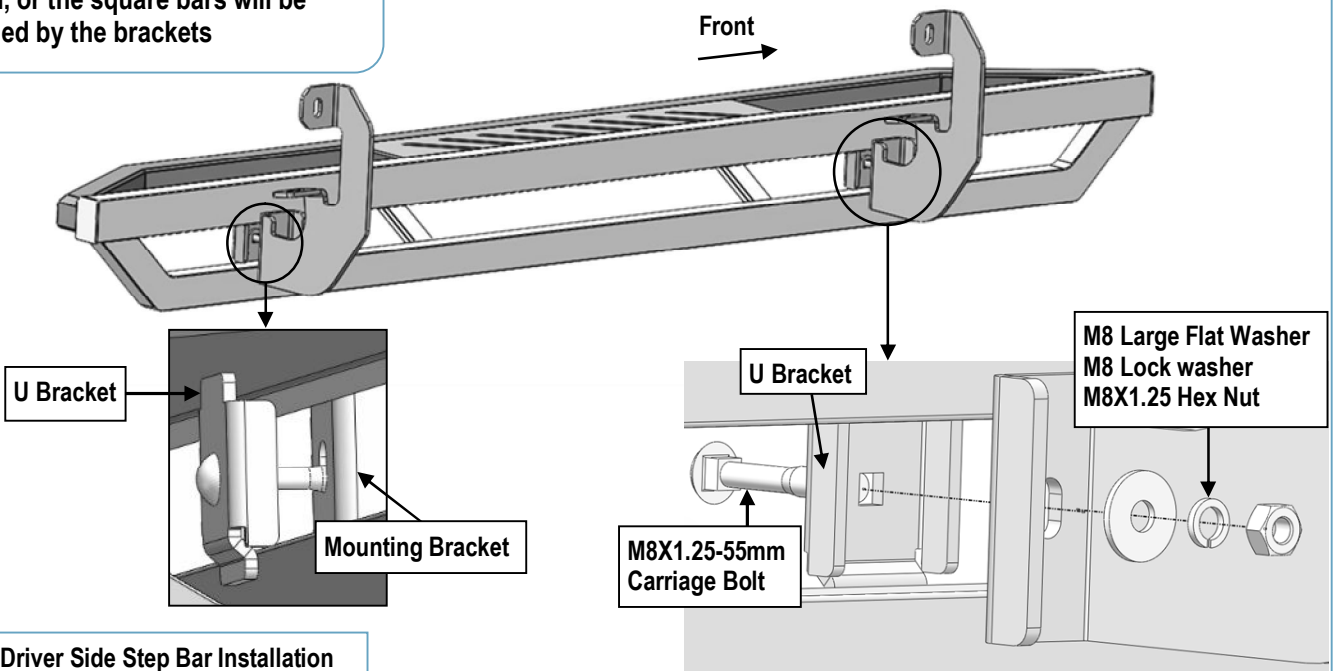

(Fig 5) Driver Side Step Bar Installation

Attention

Do periodic inspections to the installation to make sure that all hardware is secure and tight.
In order to protect your bars/boards, please use mild soap/non-abrasive products for cleaning only.