

iArmor®

iArmor® by APS

PART#: IA-S296

BEFORE INSTALLATION

REMOVE CONTENTS FROM BOX. VERIFY ALL PARTS ARE PRESENT. READ INSTRUCTIONS CAREFULLY BEFORE STARTING INSTALLATION. ASSISTANCE IS RECOMMENDED. THANK YOU FOR CHOOSING OUR PRODUCT!

*ROCKER PANEL MOUNT

*NO DRILLING /TRIMMING REQUIRED

Fastener Size	Tightening Torque (ft-lbs)	Required
6mm	6-7	X
8mm	16-18	√
10mm	31-32	X
12mm	56-58	X
14mm	92-94	X

Item	QTY	Description	Item	QTY	Description
1#	2	Driver Front & Rear Mounting Brackets	6#	12	M8 Large Flat Washers
2#	2	Passenger Front & Rear Mounting Brackets	7#	12	M8 Lock Washers
3#	4	U Brackets	8#	4	M8X1.25-55mm Carriage Bolts
4#	8	Spacers	9#	4	M8X1.25 Hex Nuts
5#	8	M8X1.25-30mm Hex Bolts			

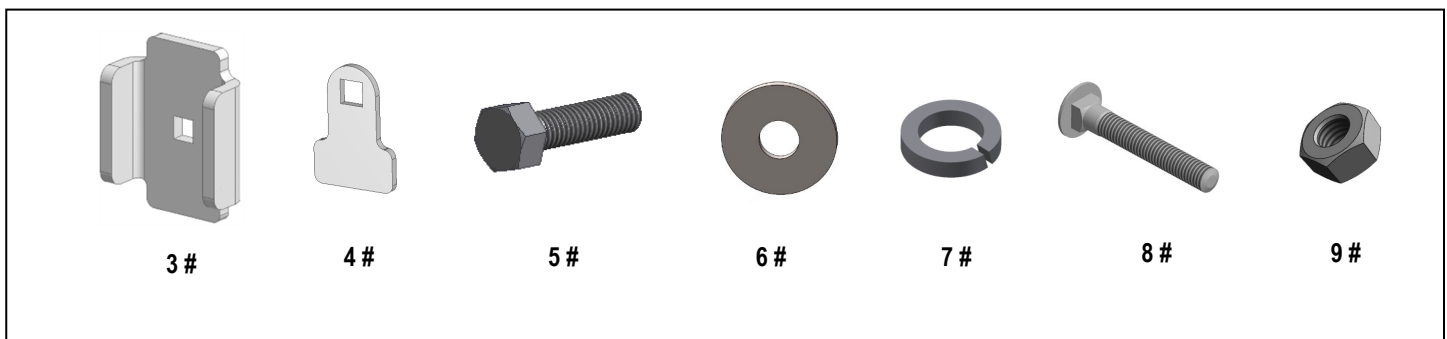

iArmor[®]

Driver

Front

Passenger

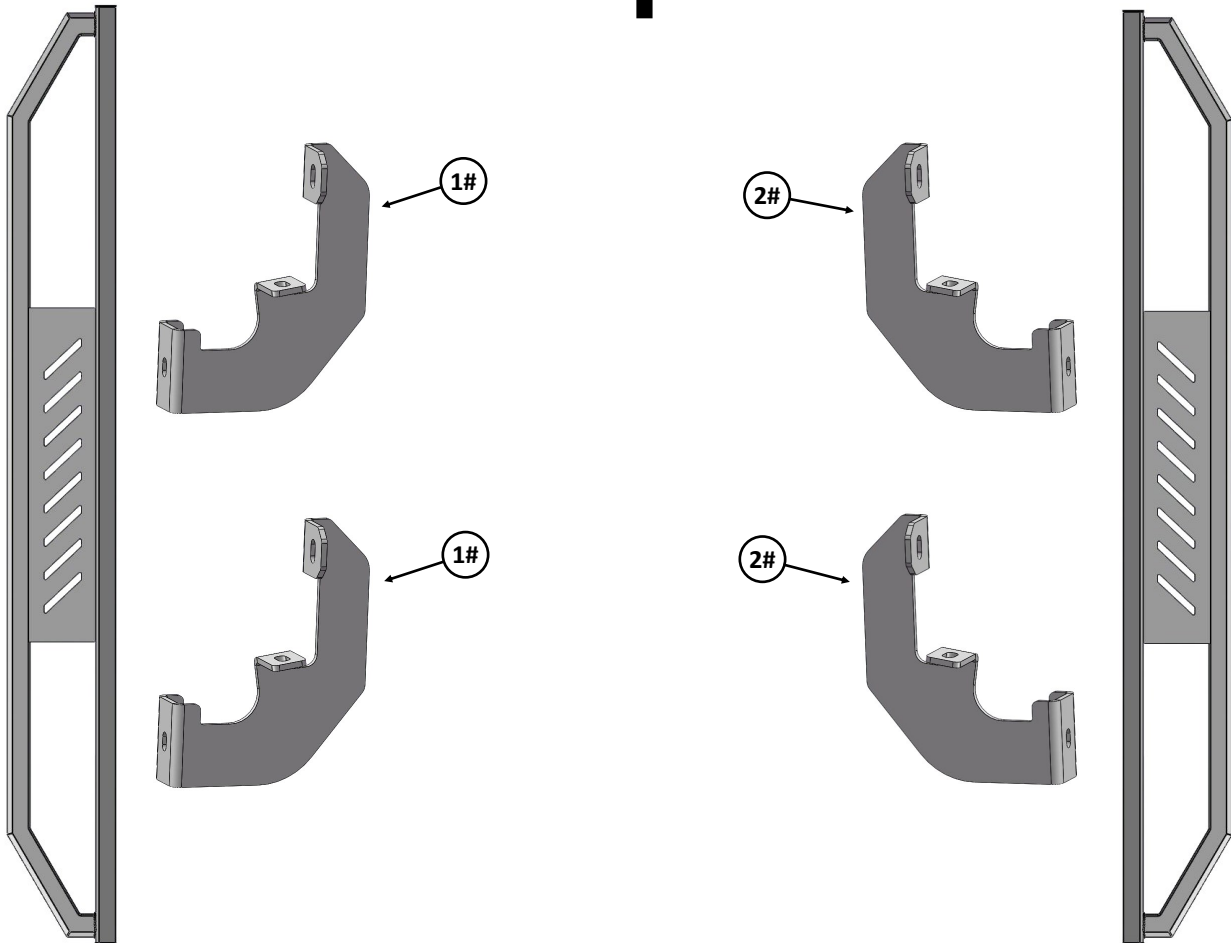

iArmor®

The instruction here is for your reference only. We strongly recommend the professional installer for best result. We are not responsible for any damage caused by the installation.

STEP 1

Start the installation under the Driver side of the vehicle. Locate the plastic plugs along the bottom edge of the body, (Fig 1). Mounting Brackets will attach to the threaded mounting holes at the front and rear of the cab. Remove the plastic plugs from the front mounting location. Directly above each threaded insert is a top mounting location on the side of the body panel. Hold a Bracket up in place to help determine the correct mounting holes to use along the body. **NOTE:** Thread an 8mm Hex Bolt into the threaded inserts to clear paint as required.

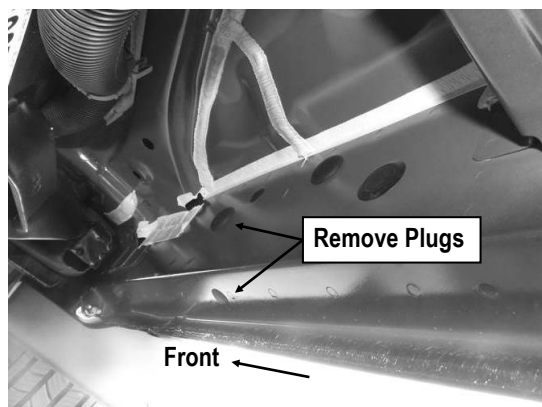

(Fig 1) Remove Plastic Plugs To Uncover Threaded Inserts

STEP 2

Start from the driver front mounting location, (Fig 2). Bolt the Driver Front Mounting Bracket to the factory threaded holes with (2) M8X1.25-30mm Hex Bolts, (2) M8 Large Flat Washers and (2) M8 Lock Washers, (Fig 3). Do not tighten hardware at this time.

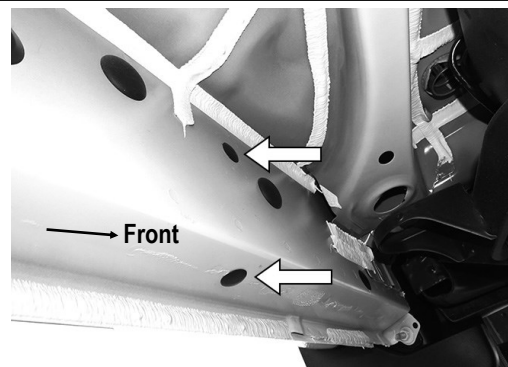

(Fig 2) Driver Front Mounting Location Pictured

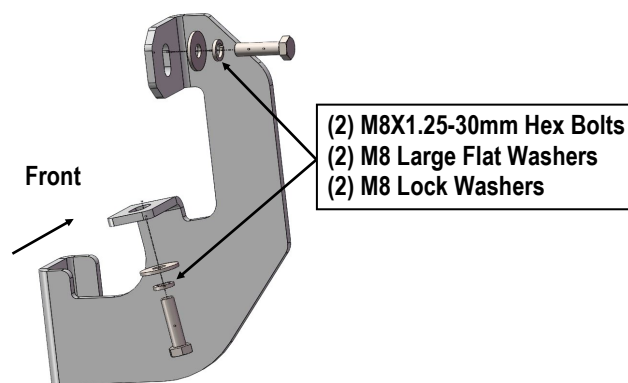

(Fig 3) Driver Front Mounting Bracket Installation

STEP 3

Move to driver side rear mounting location, (Fig 4). Repeat Step 2 to bolt the Driver Rear Mounting Bracket to the factory threaded holes.

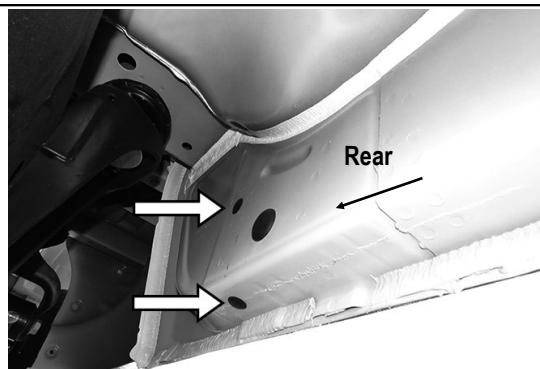

(Fig 4) Driver Rear Mounting Location Pictured

iArmor®

STEP 4

Once all (2) driver side mounting brackets are installed, select and attach the Driver Side Step Bar onto the Mounting Brackets with (2) U Brackets, (4) Spacers, (2) M8X1.25-55mm Carriage Bolts, (2) M8 Large Flat Washers, (2) M8 Lock Washers and (2) M8X1.25 Hex Nuts (**Fig 5**). Do not fully tighten hardware at this time.

STEP 5

Properly level and adjust the Step Bar and fully tighten all hardware.

STEP 6

Move to the passenger side of the vehicle. Repeat **Steps 1-5** to install the passenger side step bar.

Installation completed.

NOTE: Torque all M8 X1.25-55mm Carriage Bolts to 16~18 lb-ft. Don't over tighten, or the aluminum square bars will be damaged by the brackets

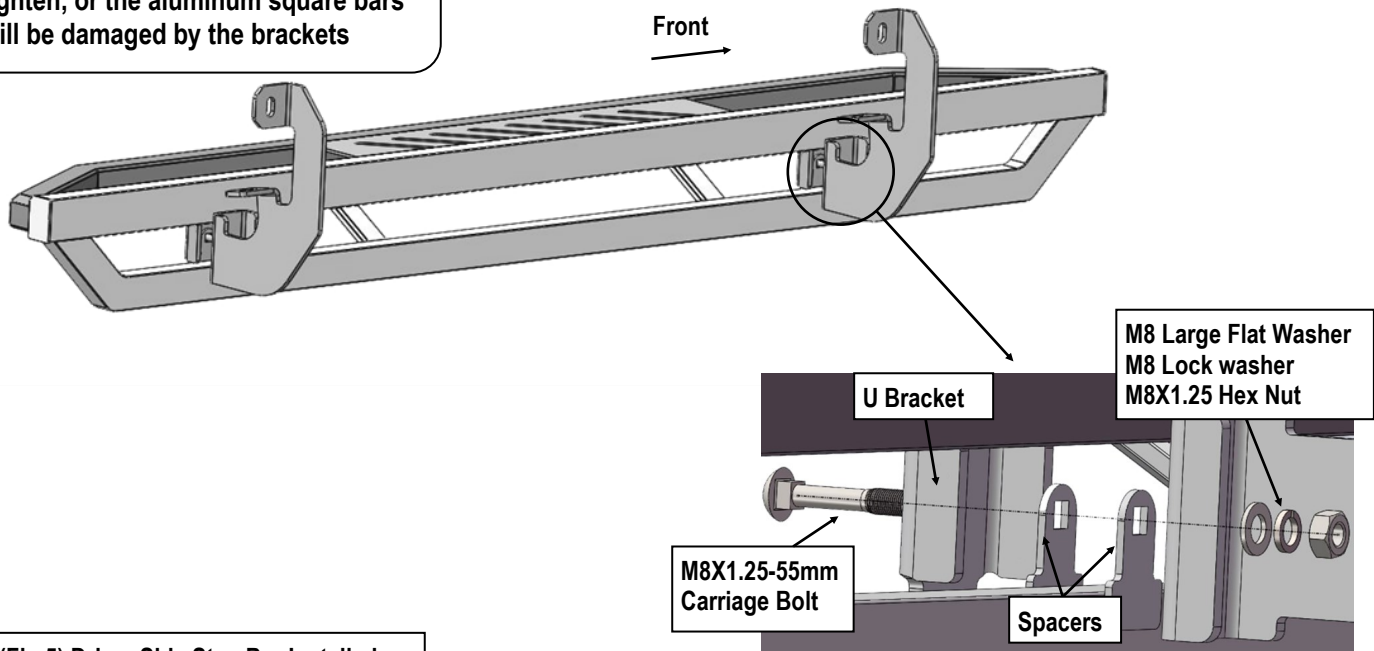

(Fig 5) Driver Side Step Bar Installed

Attention

Do periodic inspections to the installation to make sure that all hardware is secure and tight. In order to protect your bars/boards, please use only mild soap/non-abrasive products for cleaning.