

iArmor[®]

iArmor[®] by APS

PART#: IA-S295H

BEFORE INSTALLATION

REMOVE CONTENTS FROM BOX. VERIFY ALL PARTS ARE PRESENT. READ INSTRUCTIONS CAREFULLY BEFORE STARTING INSTALLATION. ASSISTANCE IS RECOMMENDED. THANK YOU FOR CHOOSING OUR PRODUCT!

*ROCKER PANEL MOUNT

*DRILLING NOT REQUIRED

Torque Value

Fastener Size	Tightening Torque (ft-lbs)	Required
6mm	6-7	X
8mm	16-18	√
10mm	31-32	X
12mm	56-58	X
14mm	92-94	X

PART LIST

Driver Side Step Bar

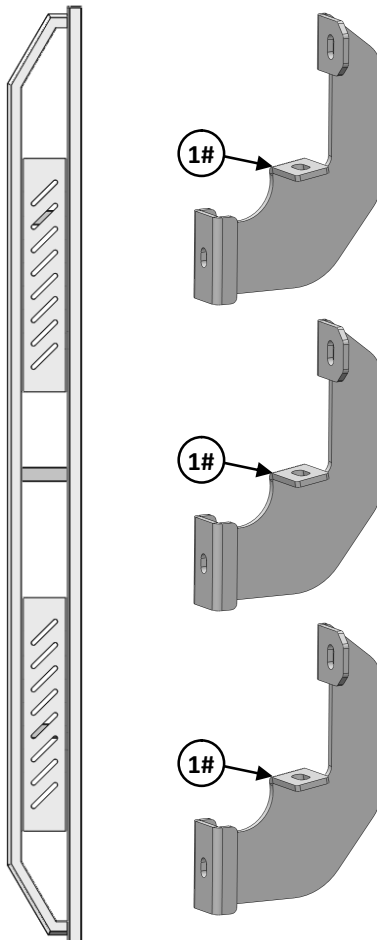

Front



Passenger Side Step Bar

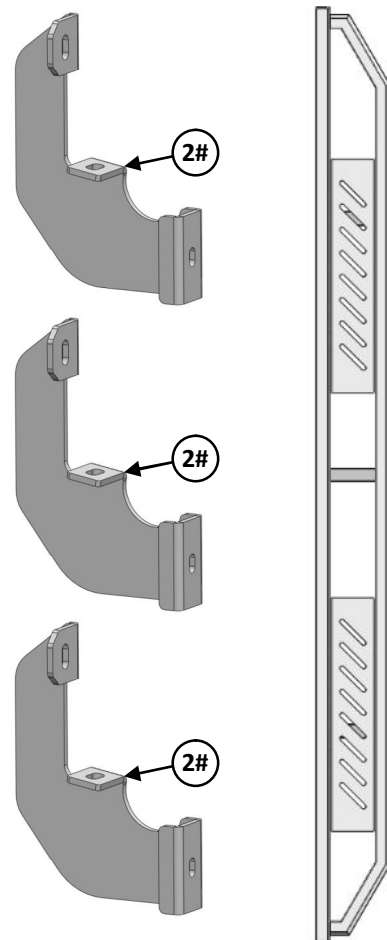

Customer Support: info@iarmorauto.com

iArmor®

Hardware Package A (For Bracket Installation)					
Item	QTY	Description	Item	QTY	Description
1#	3	Driver Front / Center / Rear Mounting Brackets	4#	12	M8X1.25-30mm Hex Bolts
2#	3	Passenger Front / Center / Rear Mounting Brackets	5#	12	M8 Large Flat Washers
3#	6	U Brackets	6#	12	M8 Lock Washers

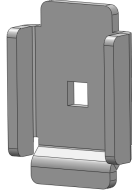

3 #



4 #



5 #



6 #

Hardware Package B (For Step Bar Installation)					
Item	QTY	Description	Item	QTY	Description
1#	6	M8X1.25-55mm Carriage Bolts	3#	6	M8 Lock Washers
2#	6	M8 Large Flat Washers	4#	6	M8 Hex Nuts

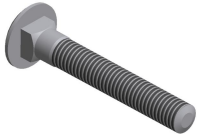

1 #



2#



3 #



4 #

iArmor®

The instruction here is for your reference only. We strongly recommend the professional installer for best result. We are not responsible for any damage caused by the installation.

STEP 1

Start the installation under the driver side of the vehicle. Locate the 6 plugs along the bottom edge of the body. Mounting Brackets will bolt to the 1st, 2nd and 4th threaded mounting holes, (Fig 1). Remove the plastic plugs from each mounting location. Directly above each threaded insert is a top mounting location on the side of the body panel.

NOTE:

*Hold a Bracket up in place to help determine the mounting holes to be use along the body.

*Thread an M8 Hex Bolt into the threaded inserts to clear paint as required.

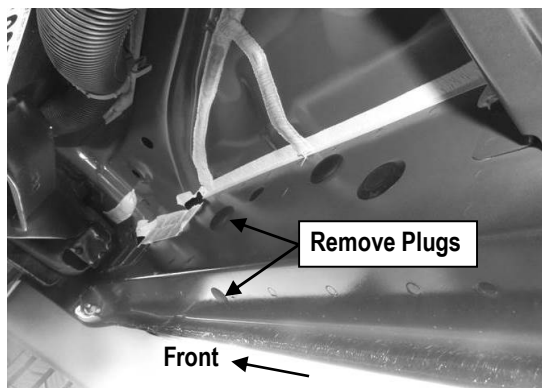

(Fig 1) Remove Rubber Covers if Equipped

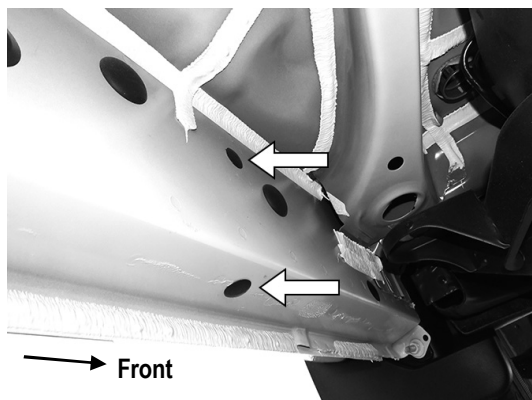

(Fig 2) Driver Side Front Mounting Location

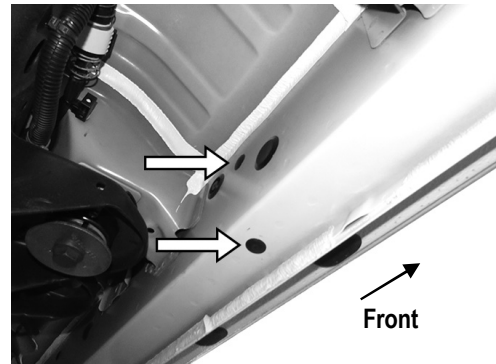

(Fig 3) Driver Side Center Mounting Location

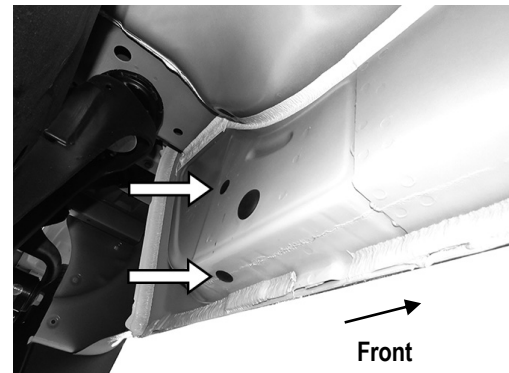

(Fig 4) Driver Side Rear Mounting Location

STEP 2

Select and bolt (1) Driver Mounting Bracket to the thread holes on Driver Side Front Mounting Location with (2) M8X1.25-30mm Hex Bolts, (2) M8 Lock Washers and (2) M8 Large Flat Washers, (Fig 5). Do not fully tighten hardware at this time.

Repeat to install other (2) Driver Side Mounting Brackets.

NOTE: All (3) Driver Mounting Brackets are universal.

STEP 3

Once all (3) driver side mounting brackets are installed, select and attach the Driver Side Step Bar onto the Mounting Brackets with (3) U Brackets, (3) M8X1.25-55mm Carriage Bolts, (3) M8 Large Flat Washers, (3) M8 Lock Washers and (3) M8X1.25 Hex Nuts (Fig 6). Do not fully tighten hardware at this time.

iArmor®

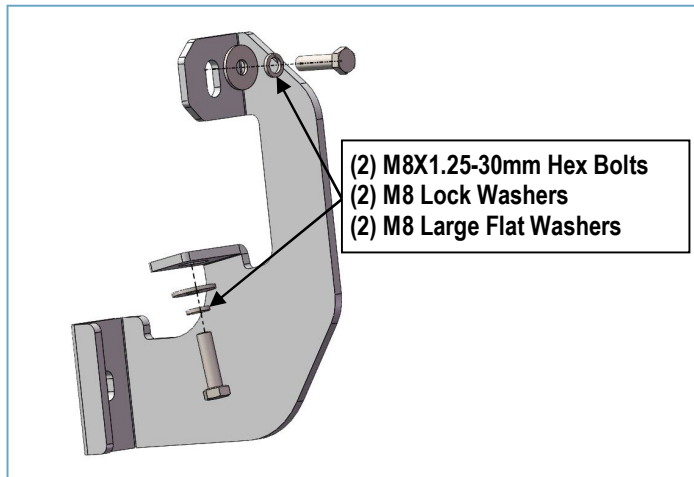

(Fig 5) Driver Front Mounting Bracket Installation

STEP 4

Properly level and adjust the Step Bar and fully tighten all hardware.

STEP 5

Move to the driver side of the vehicle. Repeat **Steps 1-4** to install the driver side step bar.

Installation completed.

NOTE: Torque all M8 X1.25-55mm Carriage Bolts to 16~18 lb-ft. Don't over tighten, or the square bars will be damaged by the brackets

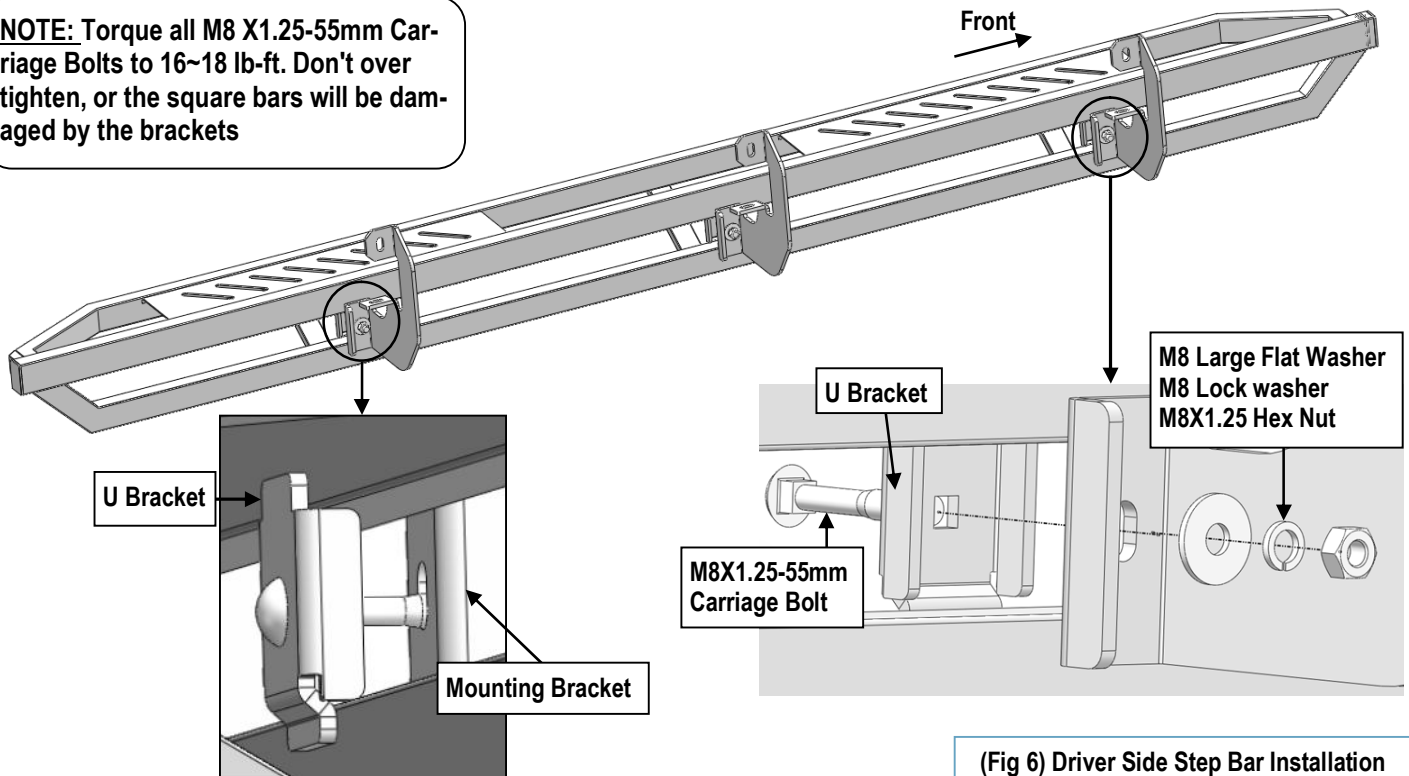

(Fig 6) Driver Side Step Bar Installation

Attention

Do periodic inspections to the installation to make sure that all hardware is secure and tight.
In order to protect your bars/boards, please use mild soap/non-abrasive products for cleaning only.