

iArmor[®]

iArmor[®] by APS

PART#: IA-S233H

BEFORE INSTALLATION

REMOVE CONTENTS FROM BOX. VERIFY ALL PARTS ARE PRESENT. READ INSTRUCTIONS CAREFULLY BEFORE STARTING INSTALLATION. ASSISTANCE IS RECOMMENDED. THANK YOU FOR CHOOSING OUR PRODUCT!

***ROCKER PANEL MOUNT**

***NO DRILLING / TRIMMING REQUIRED**

Torque Value

Fastener Size	Tightening Torque (ft-lbs)	Required
6mm	6-7	X
8mm	16-18	√
10mm	31-32	√
12mm	56-58	X
14mm	92-94	X

PART LIST

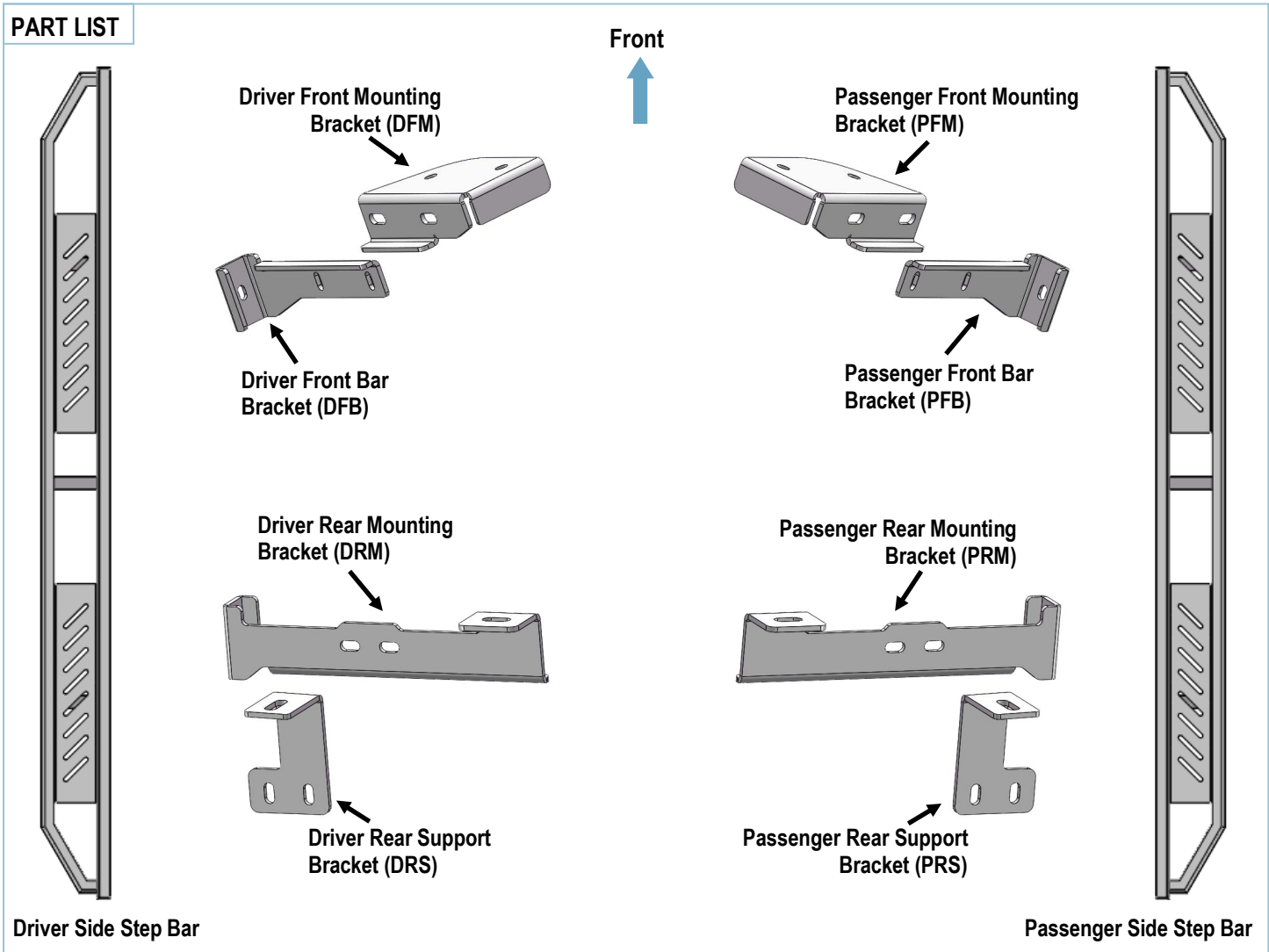

Customer Support: info@iarmorauto.com

iArmor®

Hardware Package A (For Bracket Installation)

Item	QTY	Description	Item	QTY	Description
1#	4	U Brackets	5#	8	M10 Large Flat Washers
2#	2	M10X40 Bolt Plate	6#	16	M10 Flat Washers
3#	6	M10X45 Bolt Plate	7#	16	M10 Lock Washers
4#	8	M10X1.5-30mm Hex Bolts	8#	16	M10X1.5 Hex Nuts

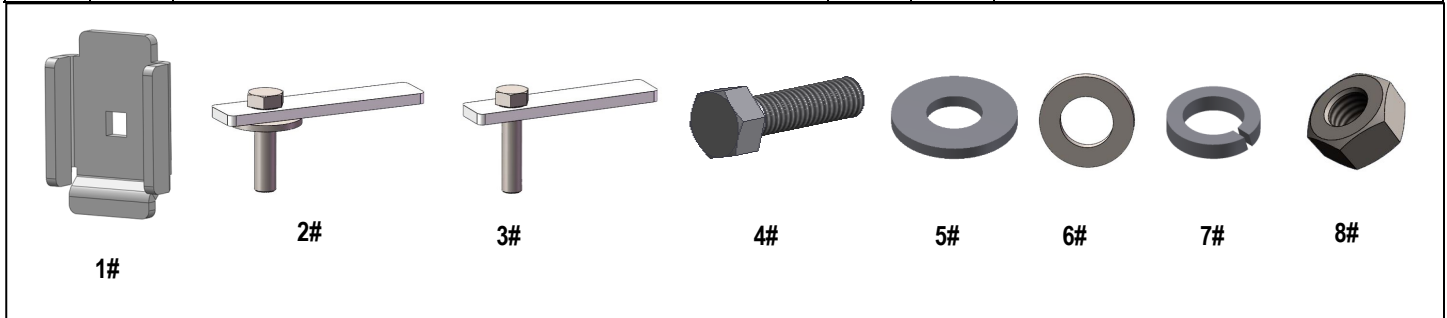

Hardware Package B (For Step Bar Installation)

Item	QTY	Description	Item	QTY	Description
1#	4	M8X1.25-55mm Carriage Bolts	3#	4	M8 Lock Washers
2#	4	M8 Large Flat Washers	4#	4	M8 Hex Nuts

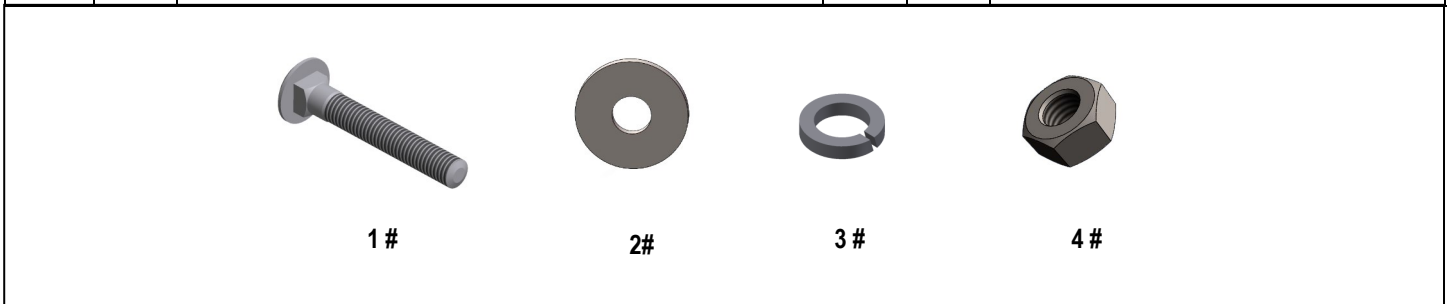

iArmor®

The instruction here is for your reference only. We strongly recommend the professional installer for best result. We are not responsible for any damage caused by the installation.

STEP 1

Starting at the driver side-front of the vehicle, locate the two large factory holes in the floor panel by the front tires, (Fig 1). Insert (1) M10x40 Bolt Plate into each of the factory holes, (Fig 2).

IMPORTANT: Once you have inserted the Bolt Plates, make sure that the welded washer on each Bolt Plate is in the center of the factory hole.

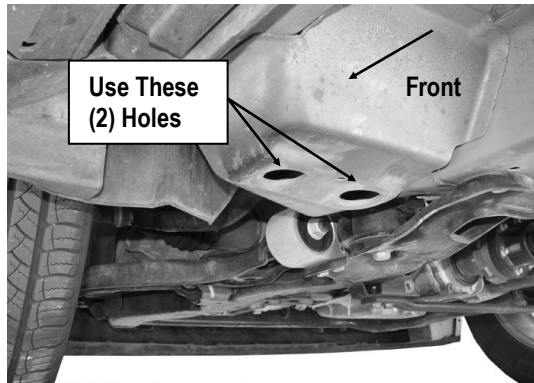

(Fig 1) Driver Side Front Mounting Location

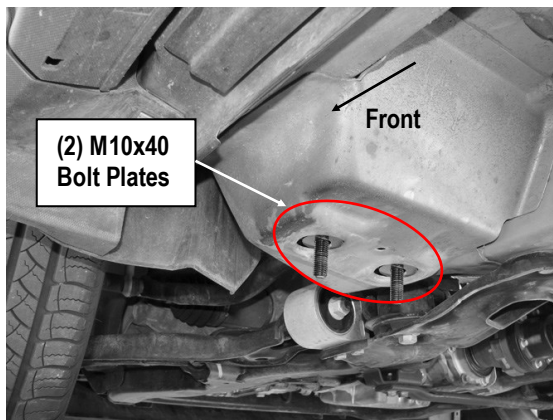

(Fig 2) M10x40 Bolt Plate With Welded Washer

STEP 2

Bolt the Driver Front Bar Bracket (DFB) to the back of the Driver Front Mounting Bracket (DFM) with the included (2) M10X1.5-30mm Hex Bolts, (4) M10 Flat Washers, (2) M10 Lock Washers and (2) M10X1.5 Hex Nuts, (Fig 3). Leave hardware loose at this time.

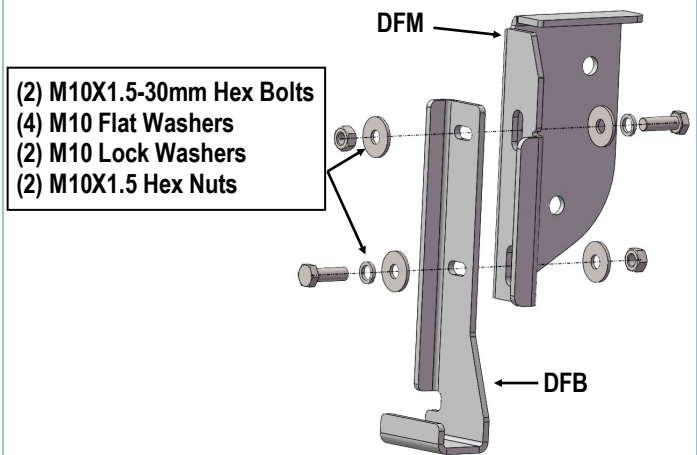

(Fig 3) Bolt the Driver Front Bar Bracket (DFB) To The Back Of The Driver Front Mounting Bracket (DFM)

STEP 3

Select the Assembled Driver Front Mounting Bracket. Bolt the bracket to the (2) M10X40 Bolt Plates with the included (2) M10 Large Flat Washers, (2) M10 Lock Washers and (2) M10X1.5 Hex Nuts, (Fig 4). Snug but do not tighten hardware at this time.

NOTE: Make sure that the welded-on washers are fully seated in the large openings in the floor at all times before tightening hardware.

iArmor[®]

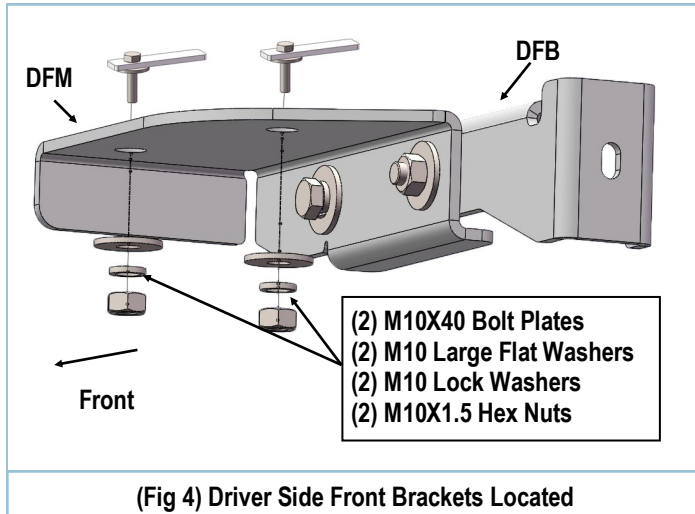

STEP 4

Move along the floor panel to the Rear of the vehicle. Select (1) M10 x 40 Bolt Plate, (1) M10 x 45 Bolt Plate (Fig 5). Insert the Bolt Plates into the (2) small holes in the bottom of the floor reinforcement. **NOTE:** The plates on the Bolt Plates should point toward each other, (Fig 6).

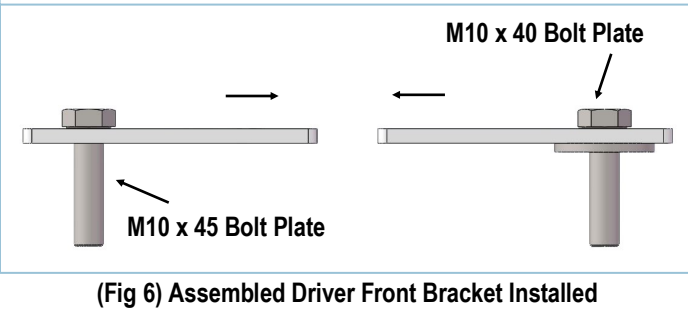
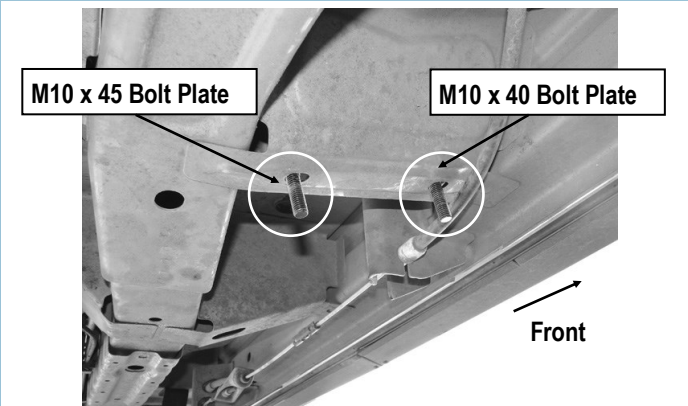

STEP 5

Attach the Driver Rear Support Bracket (DRS) to the Driver Rear Mounting Bracket (DRM) with (2) M10X1.5-30mm Hex Bolts, (4) M10 Flat Washers, (2) M10 Lock Washers and (2) M10X1.5 Hex Nuts, (Fig 7).

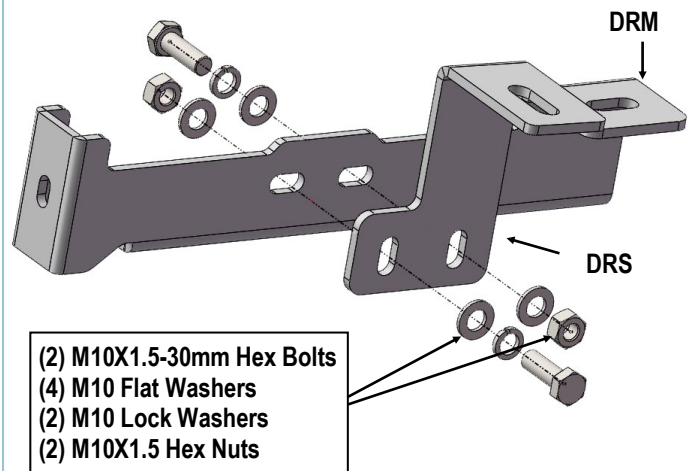

STEP 7

Once all (2) driver side mounting brackets are installed, select and attach the Driver Side Step Bar onto the Mounting Brackets with (2) U Brackets, (2) M8X1.25-55mm Carriage Bolts, (2) M8 Large Flat Washers, (2) M8 Lock Washers and (2) M8X1.25 Hex Nuts (Fig 9). Do not fully tighten hardware at this time. Properly level and adjust the Step Bar and fully tighten all hardware.

STEP 6

Select the Driver Rear Support Bracket (DRS). Hang the Support Bracket from the M10X40 Bolt Plate with (1) M10 Large Flat Washer, (1) M10 Lock Washer and (1) M10X1.5 Hex Nut, (Fig 8). Leave loose at this time. Next, repeat to attach the Driver Rear Mounting Bracket (DRM) to the inner M10 x 45 Bolt Plate, (Fig 8). Leave hardware loose at this time.

iArmor®

STEP 8

Properly level and adjust the Step Bar and fully tighten all hardware.

STEP 9

Move to the passenger side of the vehicle. Repeat **Steps 1-8** to install passenger side step bar.

Installation completed.

Attention

Do periodic inspections to the installation to make sure that all hardware is secure and tight.

In order to protect your bars/boards, please use mild soap/non-abrasive products for cleaning only.

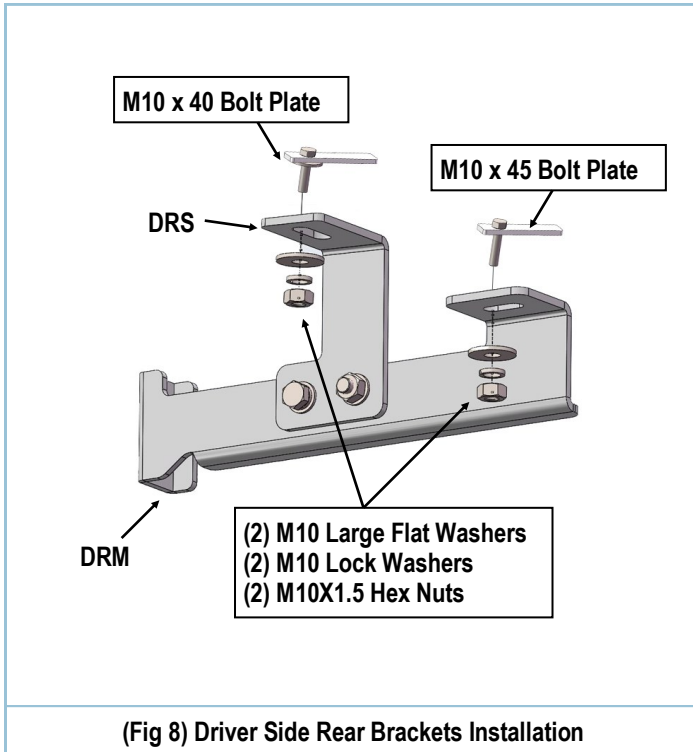

(Fig 9) Driver Side Step Bar Installation

NOTE: Torque all M8 X1.25-55mm Carriage Bolts to 16~18 lb-ft. Don't over tighten, or the square bars will be damaged by the brackets

