

## IARMOR EDGE™

PART#: IA-N007

### BEFORE INSTALLATION

REMOVE CONTENTS FROM BOX. VERIFY ALL PARTS ARE PRESENT. READ INSTRUCTIONS CAREFULLY BEFORE STARTING INSTALLATION. ASSISTANCE IS RECOMMENDED. THANK YOU FOR CHOOSING OUR PRODUCT!

\*DRILLING NOT REQUIRED

\*TRIMMING NOT REQUIRED

### Torque Value

Fastener Size	Tightening Torque (ft-lbs)	Required
6mm	6-7	√
8mm	16-18	X
10mm	31-32	√
12mm	56-58	X
14mm	92-94	X

### PART LIST

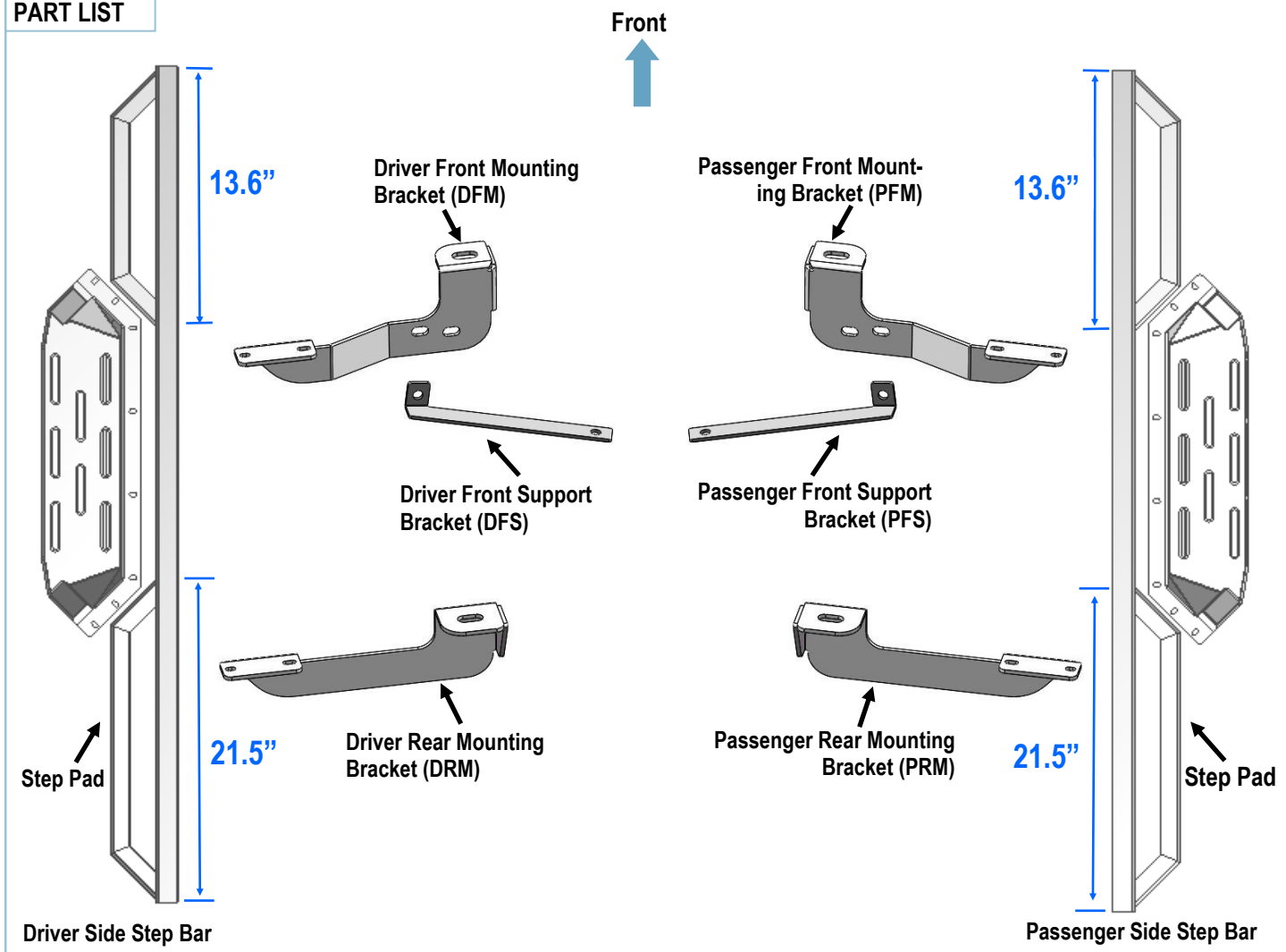

Customer Support: [info@iarmorauto.com](mailto:info@iarmorauto.com)

# iArmor®

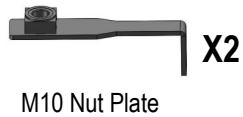

M10 Nut Plate

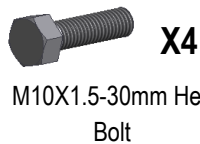

M10X1.5-30mm Hex Bolt



M10 Flat Washer



M10 Lock Washer



M10X1.5 Hex Nut



M6X1-20mm T-Bolt



M6 Large Flat Washer



M6X1 Nylon Lock Nut

The instruction here is for your reference only. We strongly recommend the professional installer for best result. We are not responsible for any damage caused by the installation.

## STEP 1

Install the Step Pads onto the step bars with (16) M6X1-20mm T-Bolts, (16) M6 Large Flat Washers and (16) M6X1 Nylon Lock Nuts.

**IMPORTANT:** Don't hit the step pad by any metal hammer within step pad installation, or the step pad will be damaged.

(8) M6X1-20 T-Bolts  
(8) M6 Flat Washers  
(8) M6 Nylon Lock Nuts

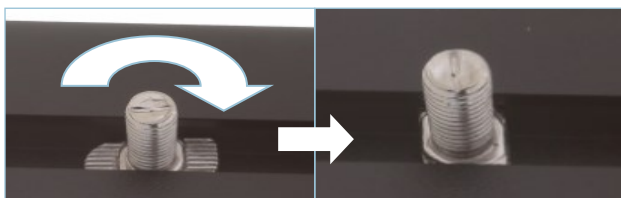

**Note: Rotate 90° after inserting the T-Bolts into the Channel!!!**

## STEP 2

Starting from the passenger side of the vehicle. Remove the front body mount bolt, (**Fig 1**). Do not remove rubber bushings.

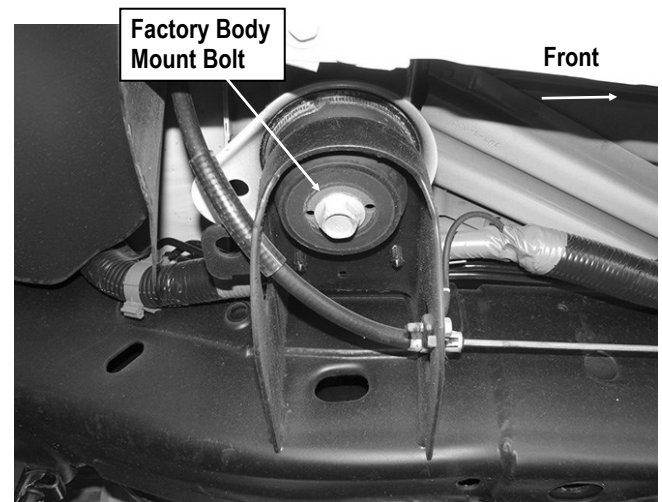

(Fig 1) Passenger Side Front Mounting Location Pictured

## STEP 3

Attach the Passenger Front Mounting Bracket (PFM) to the body mount reusing the factory hex bolt, (**Fig 2**). Do not fully tighten hardware at this time.

# iArmor®

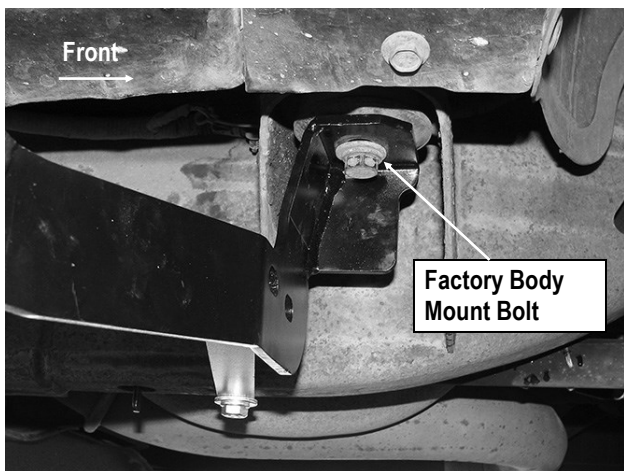

(Fig 2) Passenger Front Mounting Bracket Installed

## STEP 4

Locate the (2) factory holes at the bottom of the frame beside the passenger side front body mount, (Fig 3). Insert (1) M10 Nut Plate into the oval hole and line up the threaded nut with the round hole, (Fig 3).

**NOTE:** Nut Plate and Support Brackets are not required on 11-Up 2500/3500 models.

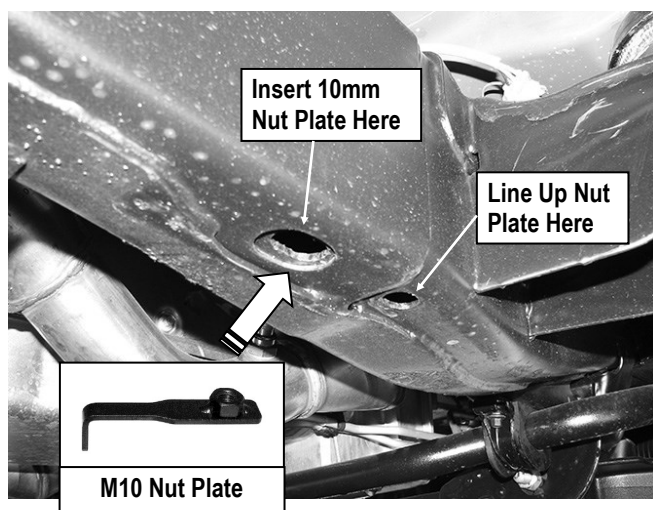

(Fig 3) Passenger Side Front Support Bracket Mounting Location

## STEP 5

Attach the flat end of the Passenger Front Support Bracket (PFS) to the installed M10 Nut Plate with (1) M10X1.5-30mm Hex Bolt, (1) M10 Flat Washer and (1) M10 Lock Washer, (Fig 4 & 5). Do not fully tighten hardware at this time.

### Up to 2010 2500/3500 Models:

Note that the Front Support Bracket will not reach up to the Mounting Bracket, (Fig 5). Tighten the Support Bracket to the M10 Nut Plate in the frame. Carefully push up on the Support Bracket until it reaches the inside hole in the Mounting Bracket. Bolt the Support Bracket to the hole in the Mounting Bracket with (1) M10X1.5-30mm Hex Bolt, (2) M10 Flat Washers, (1) M10 Lock Washer and (1) M10X1.5 Hex Nut, (Figs 5 & 6). Do not fully tighten hardware at this time.

**NOTE:** Bend Support Bracket up by hand to meet the inner hole in the Front Mounting Bracket.

**Support Bracket not required on 2011-Up 25-3500 Models.**

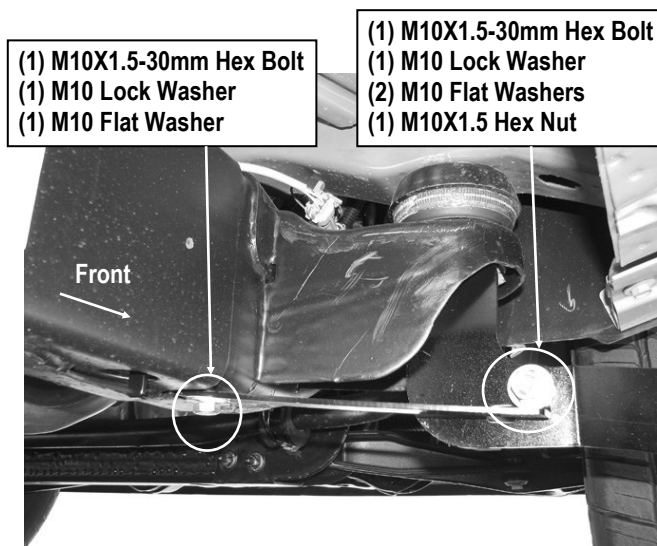

(Fig 4) Passenger Front Support Bracket Installation

# iArmor®

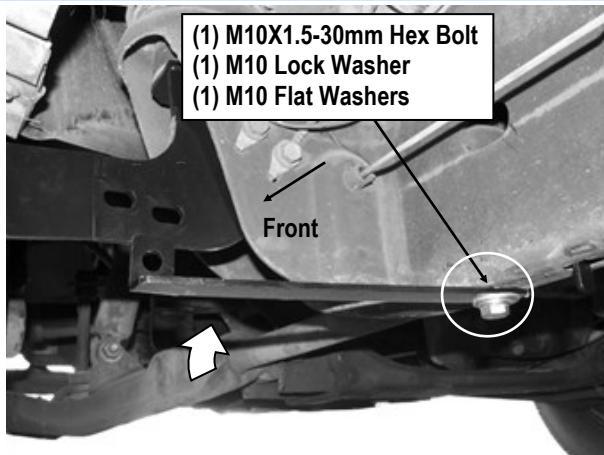

(Fig 5) Passenger Front Support Bracket Installation

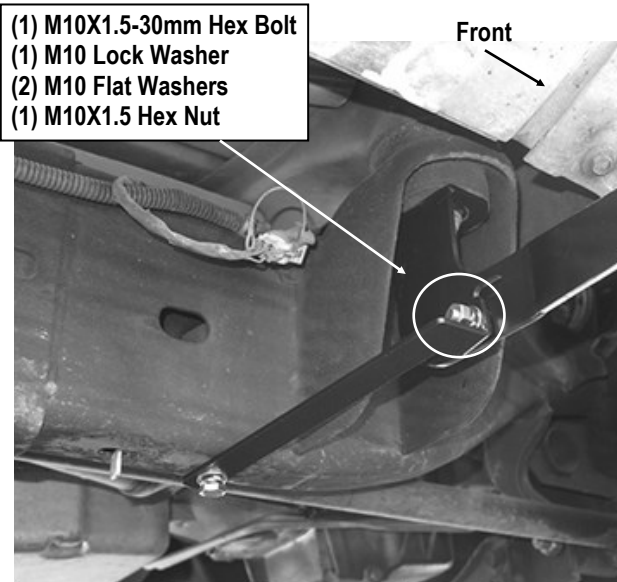

(Fig 6) Passenger Front Support Bracket Installation

## STEP 6

Move to the Passenger Side Rear body mount. Repeat **Steps 2-5** to attach the Passenger Rear Mounting Bracket to the body mount, (Fig 7). Do not fully tighten hardware at this time.



(Fig 7) Passenger Rear Mounting Bracket Installation

## STEP 7

Once (2) passenger side brackets are installed, attach the Assembled Passenger Side Step Bar onto the Mounting Brackets with (4) M6X1-20 T-Bolts, (4) M6 Large Flat Washers and (4) M6x1 Nylon Lock Nuts, (Fig 8). Do not fully tighten hardware.

## STEP 8

Properly level and adjust the Step Bar and fully tighten all hardware.

## STEP 9

Move to the Driver side of the vehicle. Repeat **Steps 2-8** for the Driver Side Step Bar installation.

# iArmor<sup>®</sup>

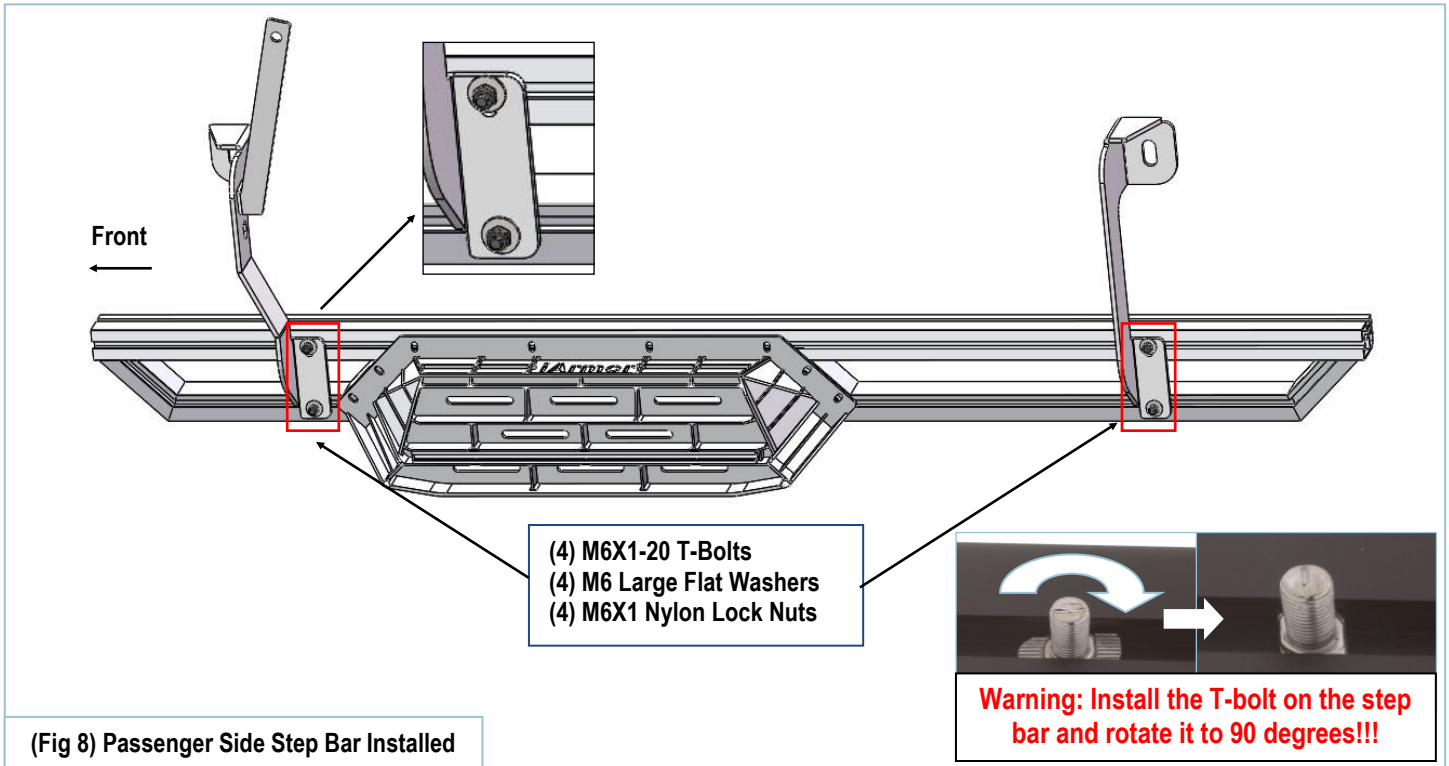

## Attention

Do periodic inspections to the installation to make sure that all hardware is secure and tight.  
In order to protect your bars/boards, please use only mild soap/non-abrasive products for cleaning.