

iArmor[®]

IARMOR EDGE™

PART#: IA-N071

BEFORE INSTALLATION

REMOVE CONTENTS FROM BOX. VERIFY ALL PARTS ARE PRESENT. READ INSTRUCTIONS CAREFULLY BEFORE STARTING INSTALLATION. ASSISTANCE IS RECOMMENDED. THANK YOU FOR CHOOSING OUR PRODUCT!

***DRILLING NOT REQUIRED**

***TRIMMING IS REQUIRED**

Torque Value

Fastener Size	Tightening Torque (ft-lbs)	Required
6mm	6-7	√
8mm	16-18	√
10mm	31-32	X
12mm	56-58	X
14mm	92-94	X

PART LIST

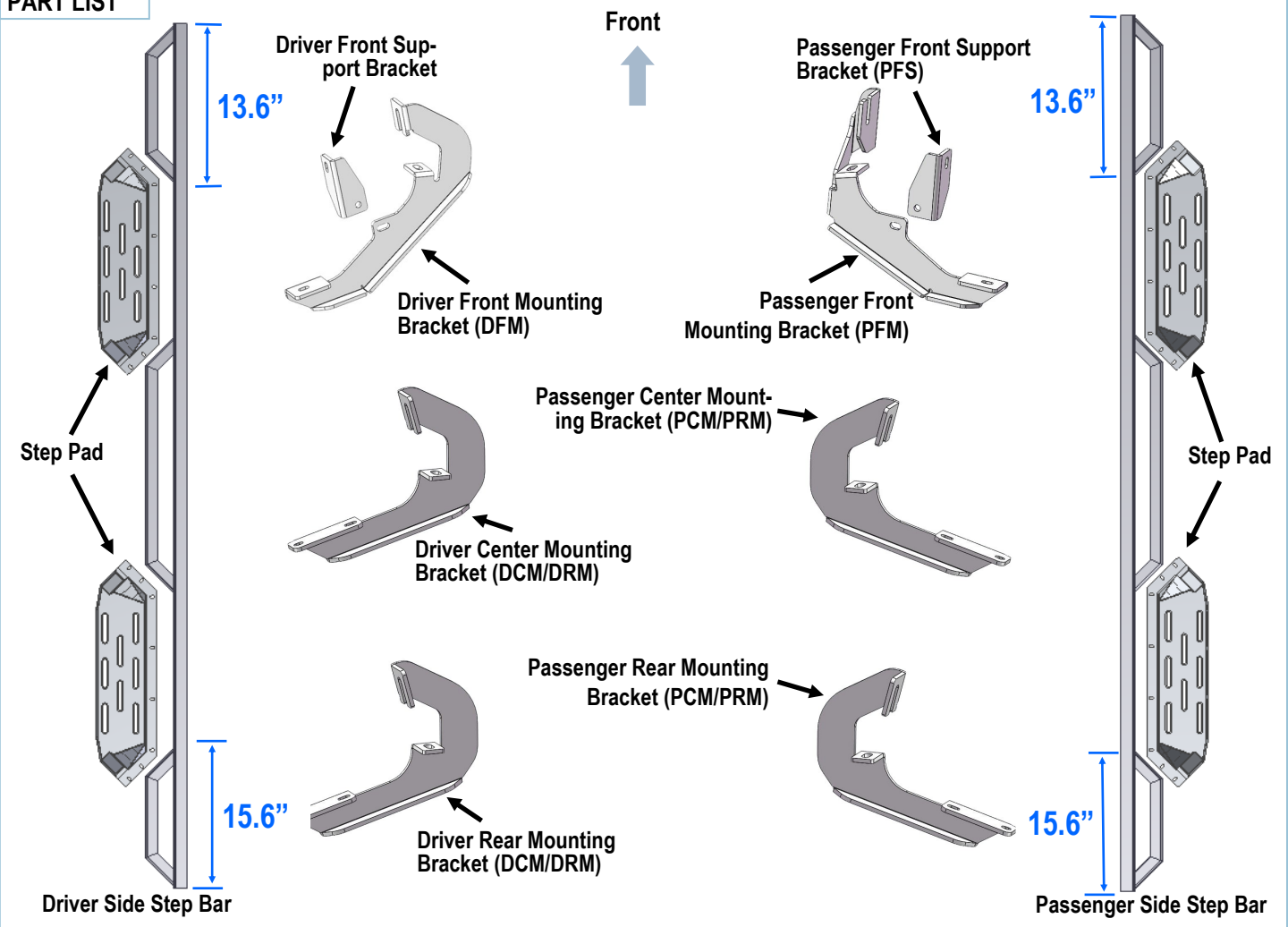

Customer Support: info@iarmorauto.com

iArmor®



X 14

M8x1.25-25mm Hex Bolt



X 16

M8 Flat Washer



X 12

M8 Lock Washer

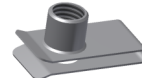

X 12

M8 Clip Nut



X 2

M8 Nylon Lock Nut

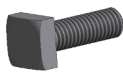

X 4

M6X1-20mm Square Head Bolt

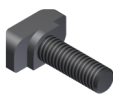

X 40

M6X1-20mm T-Bolt



X 44

M6 Large Flat Washer



X 44

M6 Nylon Lock Nut

The instruction here is for your reference only. We strongly recommend the professional installer for best result. We are not responsible for any damage caused by the installation.

STEP 1

Install the Step Pads onto the step bars with (32) M6X1-20mm T-Bolts, (32) M6 Large Flat Washers and (32) M6X1Nylon Lock Nuts.

IMPORTANT: Don't hit the step pad by any metal hummer within step pad installation, or the step pad will be damaged.

(8) M6X1-20 T-Bolts
(8) M6 Flat Washers
(8) M6 Nylon Lock Nuts

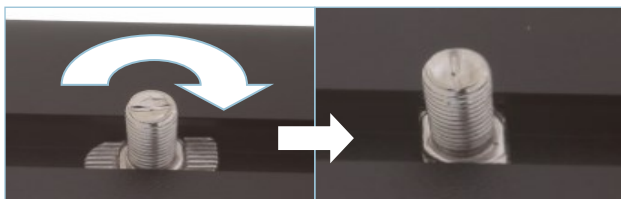

Note: Rotate 90° after inserting the T-Bolts into the Channel!!!

STEP 2

Assemble following mounting brackets and support brackets together with (1) M8X1.25-25mm Hex Bolt, (2) M8 Flat Washers and (1) M8 Nylon Lock Nut:

- (1) Driver Front Mounting Bracket (**DFM**) & Driver Front Support Bracket (**DFS**) (**Fig 1**).
- (2) Passenger Front Mounting Bracket (**PFM**) & Passenger Front Support Bracket (**PFS**) (**Fig 2**).

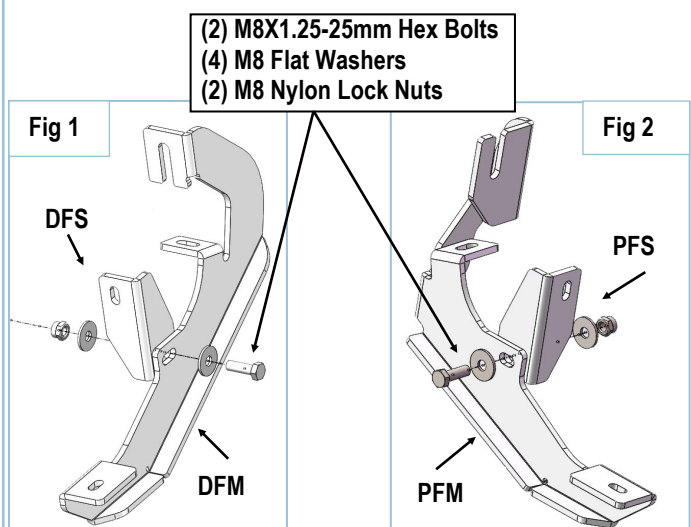

iArmor®

STEP 3

Start the installation under the driver side of the vehicle. Locate the 5 tabs along the bottom edge of the body, (pinch weld). Mounting Brackets will bolt to the **1st, 2nd and 5th** mounting tabs, (**Fig 4**). Directly above each tab is a top mounting location on the side of the body panel. Hold a bracket up in place to help determine the mounting holes to use along the body.

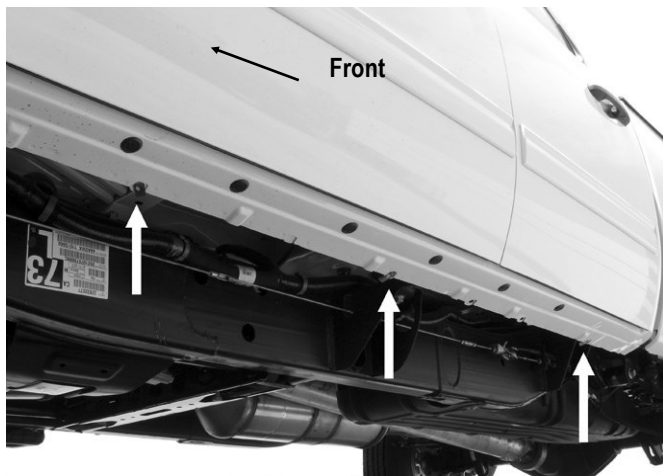

(Fig 3) Driver Side (3) Mounting Locations

STEP 4

Determine the correct procedure for your model year and each bracket location.

- (1) Locate bottom mounting location on the edge of the pinch weld:
 - a) Flat tab on pinch weld with factory installed weld nut:
Thread hex bolt into weld nut from the backside-down to clear paint from threads, (**Fig 4**).
 - b) Flat tab on pinch weld with hole:
Select (1) M8 Clip-on Nut. Slide the Clip-on Nut over the tab with the nut facing up behind the tab, (**Figs 5-7**).

Line up threaded nut with hole in the tab. Repeat for each mounting location.

- (2) Locate top mounting location on the back side of the body panel:
 - a) Models with factory installed threaded insert in body panel:
Thread 8mm Hex Bolt into threaded insert to clear paint as required, (**Figs 4 & 5**).
 - b) Large and small hole in side of body panel:
Remove the rubber plug from the larger hole, (**Fig 6**). Select (1) M8 Clip-on Nut. Slide the Clip Nut into the larger hole. Line up the threaded nut with the smaller hole, (**Fig 7**).

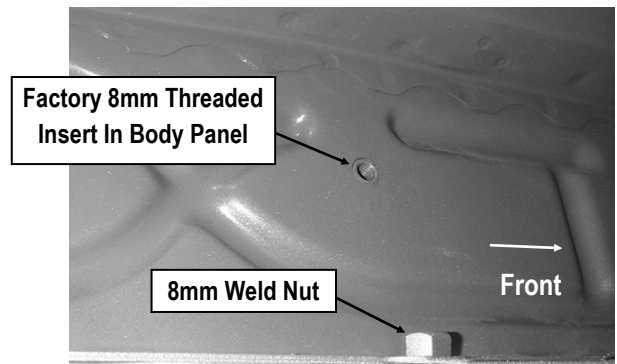

(Fig 4) Driver Side Front Mounting Location

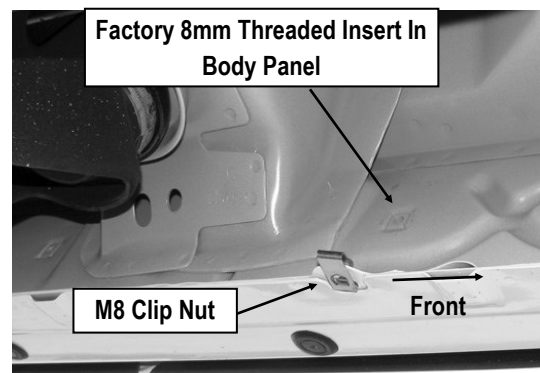

(Fig 5) Driver Side Center Mounting Location

iArmor®

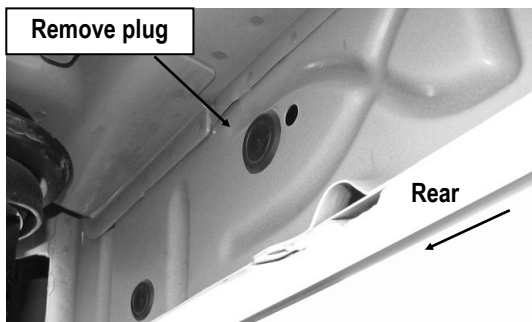

(Fig 6) Driver Side Rear Mounting Location

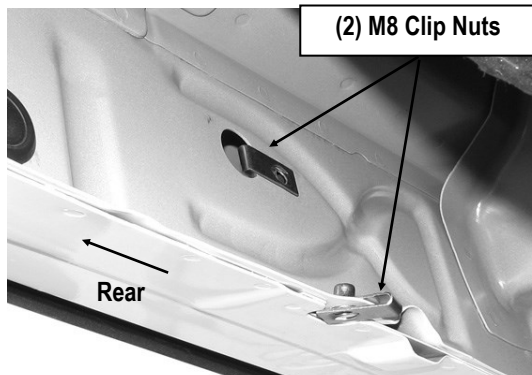

(Fig 7) Driver Side Rear Mounting Location

STEP 5

Select the assembled Driver Front Mounting Bracket. Bolt the assembled Mounting Bracket to the Clip Nuts and/or the factory threaded holes with (2) M8X1.25- 25mm Hex Bolts, (2) M8 Lock Washers and (2) M8 Flat Washers, **(Fig 8)**. Do not tighten hardware.

STEP 6

Repeat **Steps 3-5** to install the (2) remaining driver side Mounting Brackets, **(Fig 9)**.

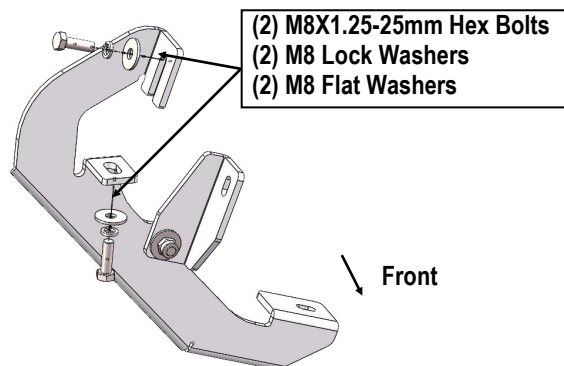

(Fig 8) Driver Front Bracket Installed



(Fig 9) Driver Center Bracket Installed

STEP 7

Select the Driver/Left Side Assembled Step Bar, attach the Step Bar to the Brackets with (4) M6X1-20mm T-Bolts, (2) M6X1-20mm Square Head Bolts, (6) M6 Large Flat Washers and (6) M6X1 Nylon Lock Nuts, **(Fig 10A & 10B)**. Do not tighten hardware at this time.

STEP 8

Level and adjust the Step Bar and fully tighten all hardware.

iArmor®

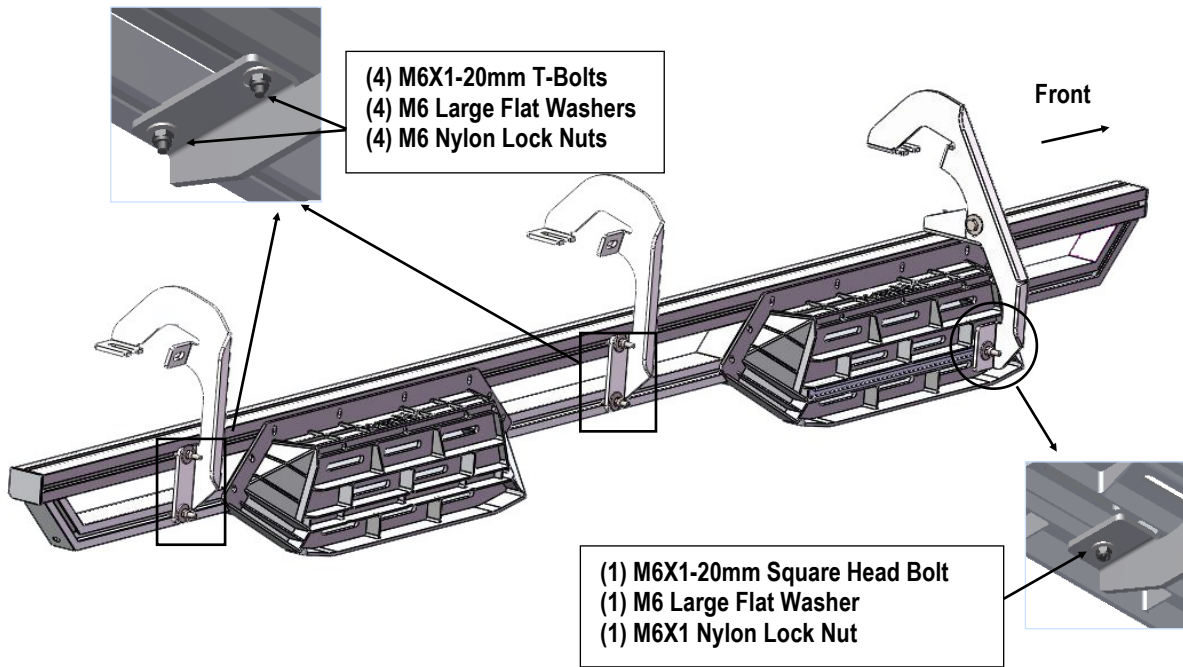

(Fig 10A) Assembled Driver Side Step Bar Installed

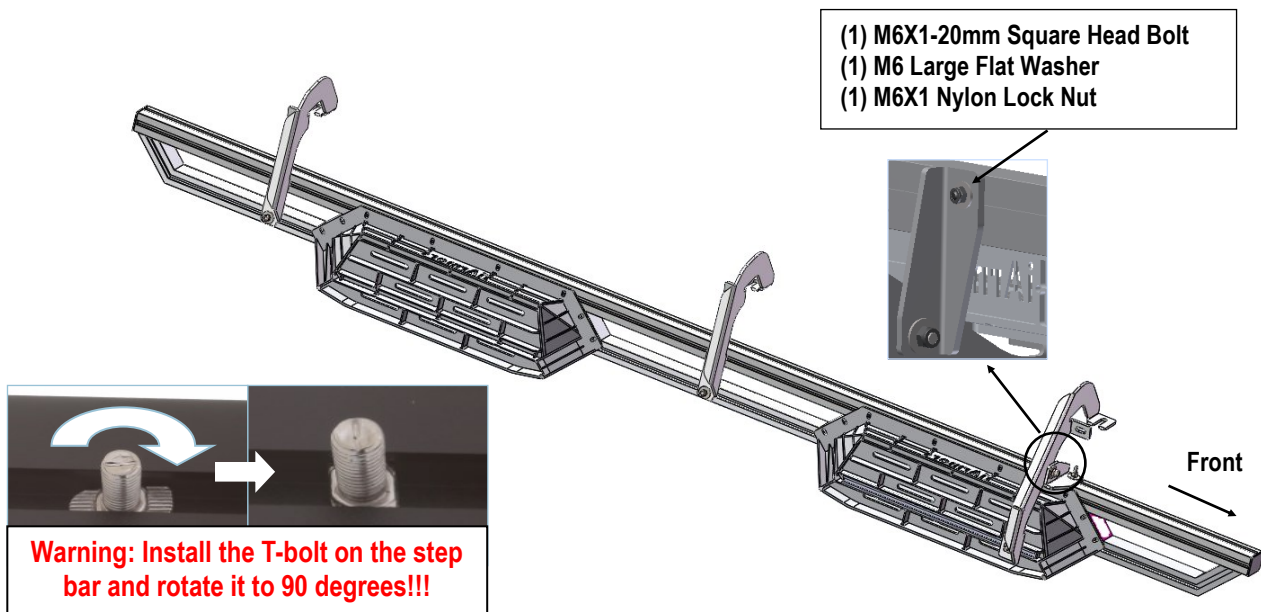

(Fig 10B) Assembled Driver Side Step Bar Installed

STEP 9

Move to the passenger side of the vehicle. On the passenger side, determine if the vehicle is equipped with a plastic diesel exhaust fluid (DEF) tank, (Fig 11 & 13).

(1) Models without DEF tank skip to Step 13.

(2) Models with DEF tank:

The tank sits close to the side of the body. With specialized tools, the Passenger Front Mounting Bracket can be installed but room is very limited. Determine model year of vehicle before proceeding.

A) Up to 2016 models:

It may be easier to drop the tank down to access the inner side of the body panel for the Passenger Side Front Mounting Bracket installation. Tank will not need to be removed, only dropped down for access to mounting location. **IMPORTANT:** If tank is full, it will be very heavy and assistance is highly recommended to avoid injury or damage to the vehicle or the tank. It is recommended that installation is performed when the DEF tank is low on fluid before dropping the tank.

- On models with plastic lower tray under the tank, remove the (3) hex bolts attaching the tray to the frame, (Fig 11), and remove the tray.
- Release the tank filler hose. Release the plug for the sending unit on the top of the tank.
- Support the tank with a floor jack. Place a smooth flat surface, (wooden block for example), between the floor jack and the tank to avoid damaging the plastic tank. Do not push up on the tank; only support the weight of the tank with the jack.
- Remove the (2) bolts securing the tank straps to the vehicle, (Fig 12). Tilt the straps to release from the brackets. Slowly lower the tank until the top of the tank is almost visible. Use blocks or stands to support the tank while installing the Passenger Front Mounting Bracket.
- Proceed to **Step 10**.

B) 2017-Up models:

- Remove the (4) hex bolts attaching plastic cover to DEF tank, (Fig 13) and remove plastic cover, (Fig 14). **NOTE:** On 2017 2500/3500 models, only remove plastic cover from DEF tank. Do not lower DEF tank and proceed to **Step 10**.



(Fig 11) 07-16 Passenger Side Front Pictured with DEF Tank Cover.

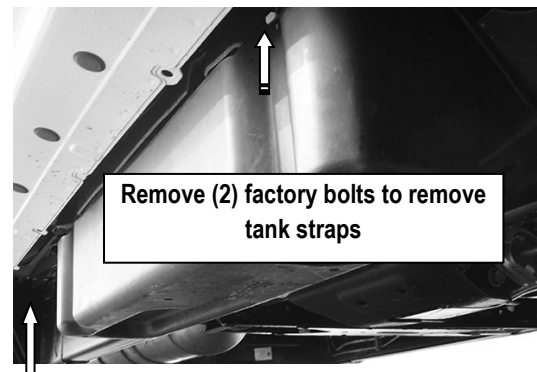

(Fig 12) 07-16 Passenger Side DEF Tank and Cover

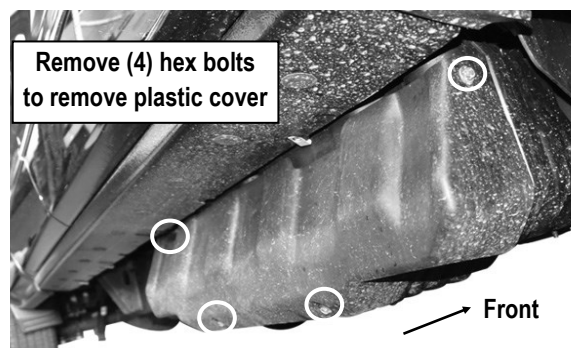

(Fig 13) 2017-Up Passenger Side Pictured w/DEF tank cover.

iArmor®

Front ←

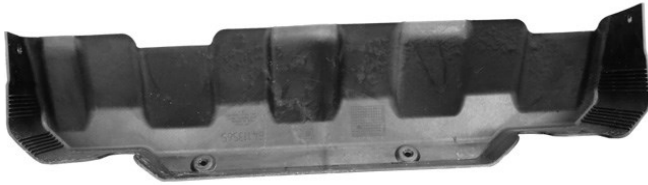

(Fig 14) 2017 Passenger Side DEF Cover Removed

STEP 10

Locate the first tab on the edge of the pinch weld, (Figs 4-7). Select the Assembled Passenger Front Mounting Bracket. Bolt the assembled Mounting Bracket to the Clip Nuts and/or the factory threaded holes with (2) M8X1.25-25mm Hex Bolts, (2) M8 Lock Washers and (2) M8 Flat Washers, (Fig 15). Do not tighten hardware.

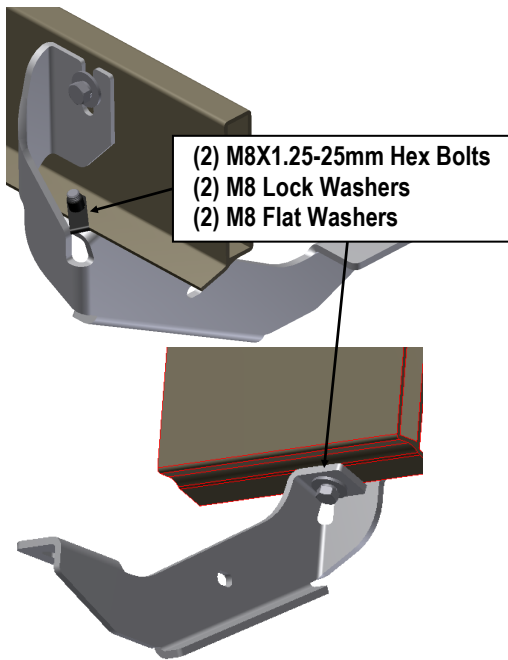

(Fig 15) Passenger Front Mounting Bracket Installed

STEP 11

2007-2016 models: Repeat **Steps 3-6** for the (2) remaining passenger side Bracket installations.

STEP 12

2017-Up 2500/3500 DEF tank models: Locate the 2nd tab bracket location along the bottom edge of the body, (pinch weld), (Fig 16). Hold the DEF cover in place and mark the location onto the cover, (Fig 17). Use a sharp knife or hacksaw blade to carefully cut a slot in the plastic cover to clear the 2nd Bracket, (Fig 18). Remove as little plastic as possible.

Front ←

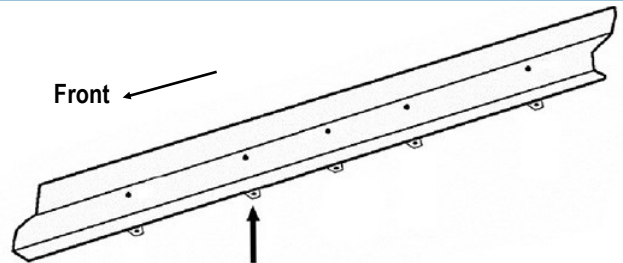

(Fig 16) Passenger Side 2nd Bracket Location from Back of Body Panel

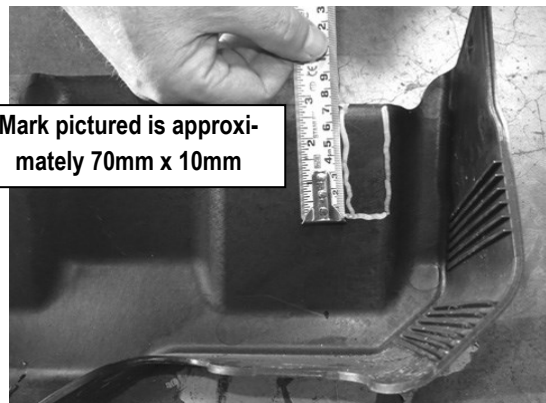

(Fig 17) 2017-Up Passenger Side DEF Cover Marked for Trimming

iArmor®

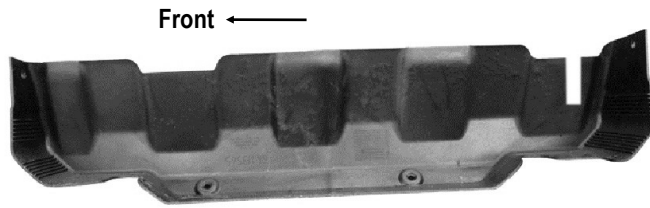

(Fig 18) 2017-Up Passenger Side DEF Cut for Example Only

STEP 13

Repeat **Steps 7 & 8** to install the Passenger Assembled Step Bar.

STEP 14

Once the Assembled Step Bar has been installed and all hardware fully tightened, reinstall the DEF tank and cover, if equipped, as described in **Step 9**.

Attention

Do periodic inspections to the installation to make sure that all hardware is secure and tight.

In order to protect your bars/boards, please use only mild soap/non-abrasive products for cleaning.