

IARMOR EDGE™

PART#: IA-N198

BEFORE INSTALLATION

REMOVE CONTENTS FROM BOX. VERIFY ALL PARTS ARE PRESENT. READ INSTRUCTIONS CAREFULLY BEFORE STARTING INSTALLATION. ASSISTANCE IS RECOMMENDED. THANK YOU FOR CHOOSING OUR PRODUCT!

*DRILLING NOT REQUIRED

*TRIMMING NOT REQUIRED

Fastener Size	Tightening Torque (ft-lbs)	Required
6mm	6-7	√
8mm	16-18	√
10mm	31-32	X
12mm	56-58	X
14mm	92-94	X

Item	QTY	Description	Item	QTY	Description
1#	3	Driver Front / Passenger Center & Rear Mounting Brackets	6#	12	M8 Clip Nuts
2#	3	Passenger Front / Driver Center & Rear Mounting Brackets	7#	44	M6X1-20mm T-Bolts
3#	12	M8X1.25-30mm Hex Bolts	8#	44	M6 Large Flat Washers
4#	12	M8 Flat Washers	9#	44	M6X1 Nylon Lock Nuts
5#	12	M8 Lock Washers			

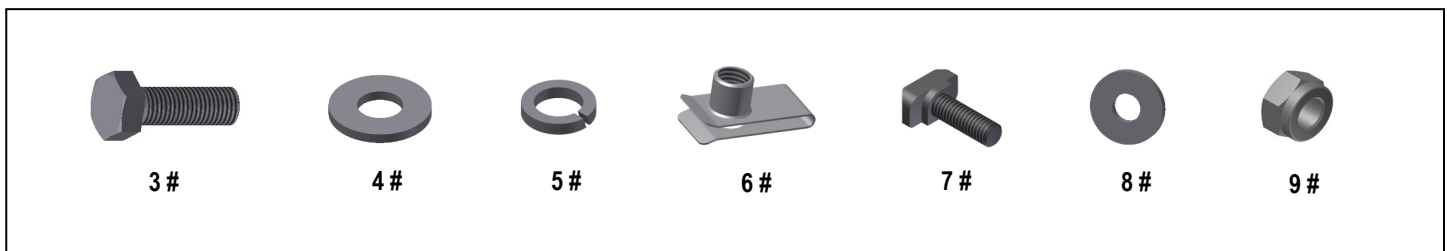

iArmor[®]

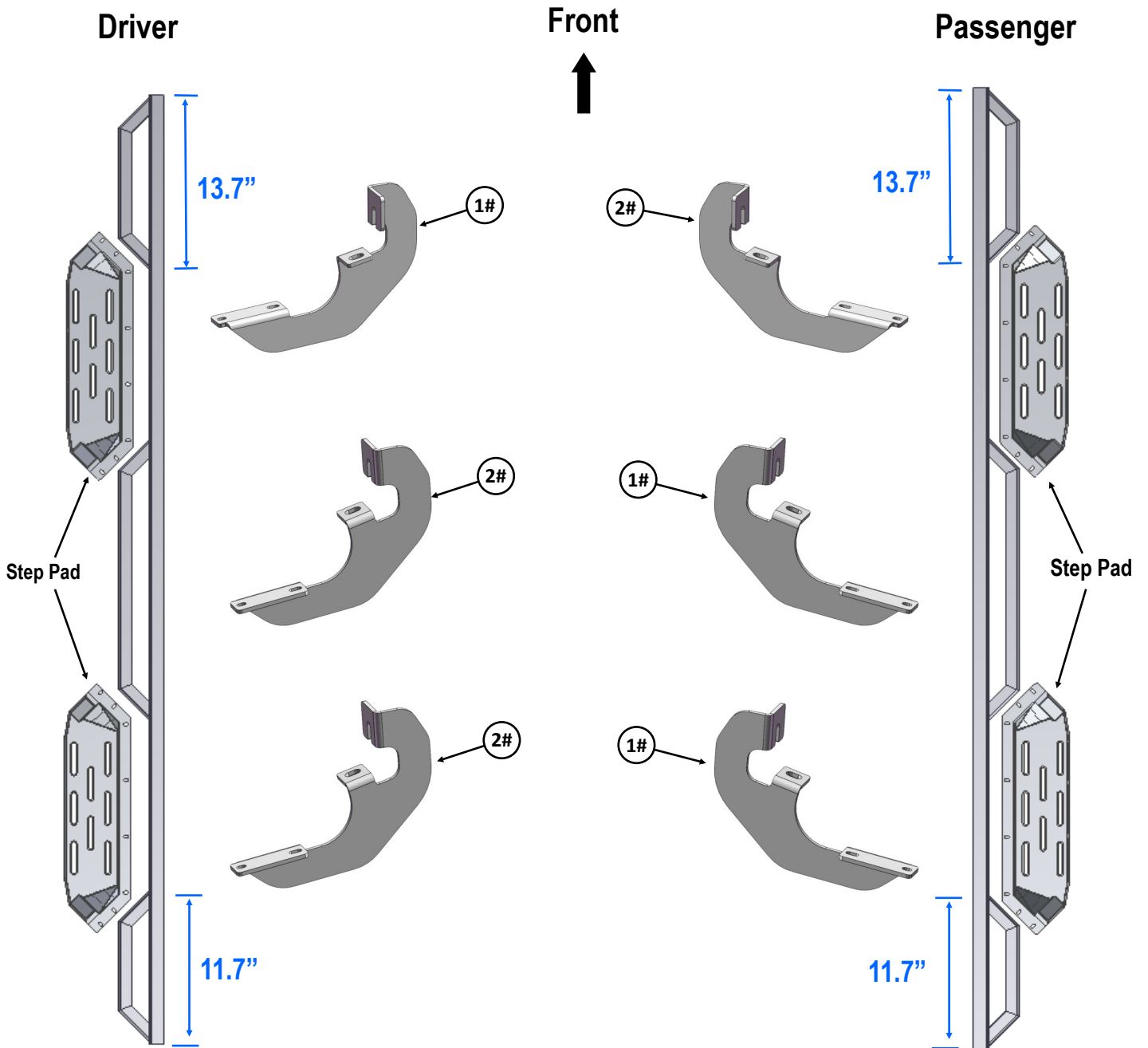

iArmor®

The instruction here is for your reference only. We strongly recommend the professional installer for best result. We are not responsible for any damage caused by the installation.

STEP 1

Install the Step Pads onto the step bars with (32) M6x1-20mm T-Bolts, (32) M6 Flat Washers and (32) M6x1 Nylon Lock Nuts.

IMPORTANT: Don't hit the step pad by any metal hammer within step pad installation, or the step pad will be damaged.

(8) M6X1-20mm T-Bolts
(8) M6 Flat Washers
(8) M6X1 Nylon Lock Nuts

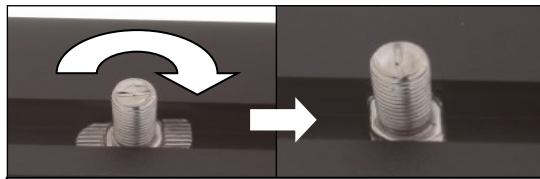

Note: Rotate 90° after inserting the T-Bolts into the Channel!!!

STEP 2

Start the installation from passenger side of the vehicle. Locate the passenger mounting locations along the bottom and inner side of the body panel, (Fig1). **NOTE:** It may help to hold a Bracket up in place to identify the mounting holes to be used along the bottom and inner side of the body panel.

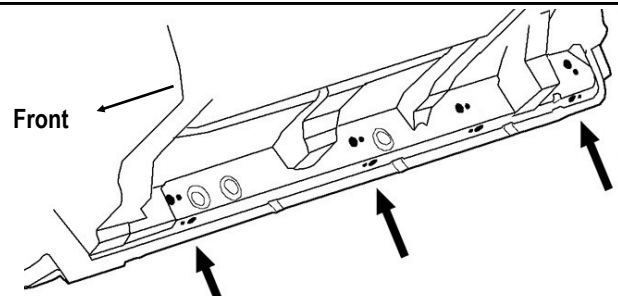

(Fig 1) Passenger side mounting locations
(Along the bottom and inner of body panel illustrated)

STEP 3

Remove rubber plugs on the Passenger Side Front Mounting Location on body panel, (Fig 2). Select (2) M8 Clip Nuts. Slide each Clip Nut into each large hole. Line up threaded nut on the Clip Nut with the smaller hole beside the large hole, (Fig 3).

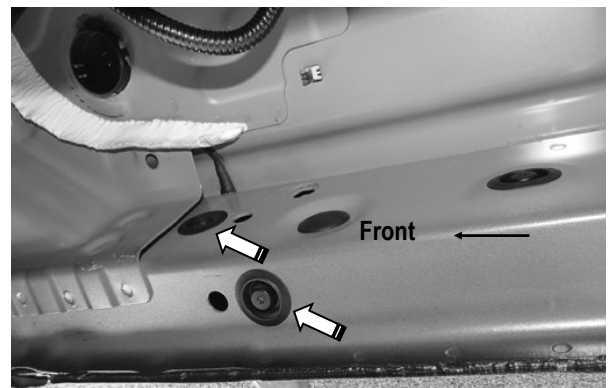

(Fig 2) Passenger Side Front Mounting Location
(Remove the rubber plugs)

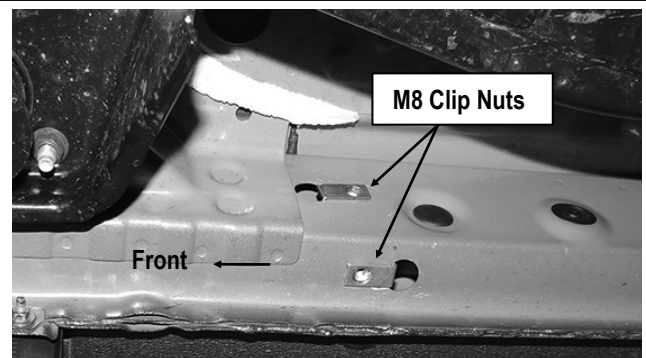

(Fig 3) M8 Clip Nuts Installed
(on the Passenger Side Front Mounting Location)

iArmor®

STEP 4

Select (1) Passenger Front Mounting Bracket. Attach the Bracket to the installed (2) M8 Clip Nuts with (2) M8X1.25-30mm Hex Bolts, (2) M8 Lock Washers and (2) M8 Flat Washers, (Figs 4 & 5). Do not fully tighten hardware at this time.

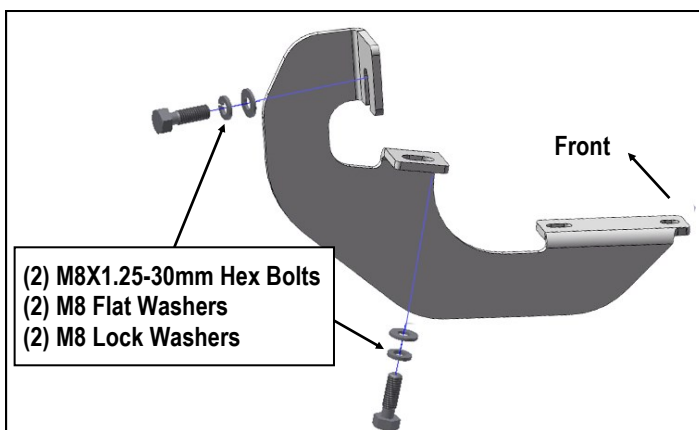

(2) M8X1.25-30mm Hex Bolts
(2) M8 Flat Washers
(2) M8 Lock Washers

(Fig 4) Passenger Front Mounting Bracket Installed

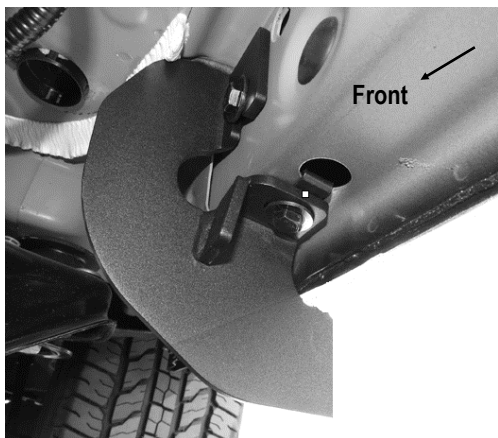

(Fig 5) Passenger Front Mounting Bracket Installed

STEP 5

Move to Passenger Side Center & Rear Mounting location along the body panel, (Figs 6 & 7). Repeat Steps 2—4 to install (1) Passenger Center Mounting Bracket and (1) Passenger Rear Mounting Bracket, (Fig 8). Do not fully tighten hardware at this time.

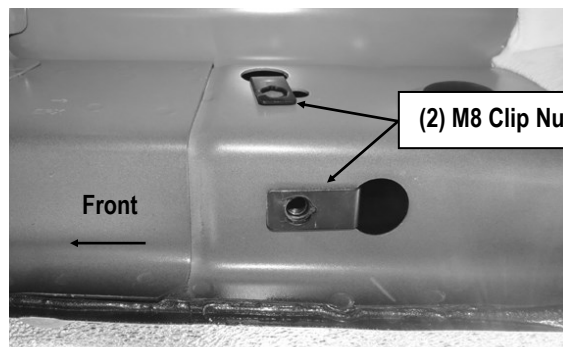

(2) M8 Clip Nuts

(Fig 6) Passenger Side Center Mounting Location

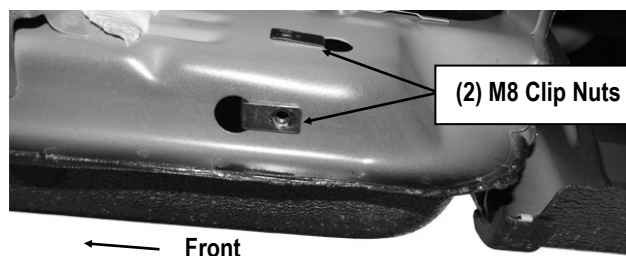

(2) M8 Clip Nuts

(Fig 7) Passenger Side Rear Mounting Location

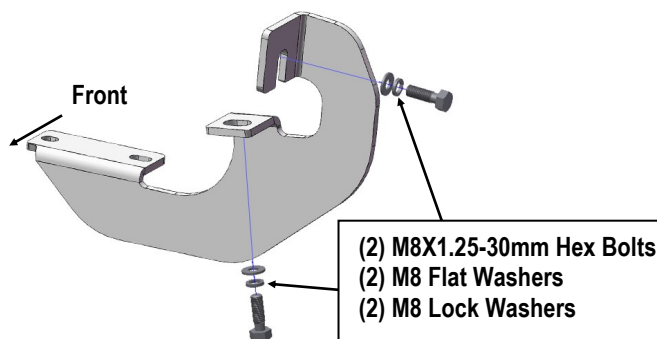

(2) M8X1.25-30mm Hex Bolts
(2) M8 Flat Washers
(2) M8 Lock Washers

(Fig 8) Passenger Center & Rear Mounting Bracket Installed

STEP 6

Once all (3) Brackets have been installed, attach the Assembled Passenger Side Step Bar to the Mounting Brackets with (6) M6X1-20mm T-Bolts, (6) M6 Large Flat Washers and (6) M6X1 Nylon Lock Nuts, (Fig 9). Do not fully tighten hardware at this time.

iArmor®

STEP 7

Properly level and adjust the Step Bar and fully tighten all hardware.

STEP 8

Move to the other side of the vehicle. Repeat **Steps 2—7** for other side Step Bar installation.

Attention

Do periodic inspections to the installation to make sure that all hardware is secure and tight.

In order to protect your bars/boards, please use only mild soap/non-abrasive products for cleaning.

(Fig 5) Assembled Driver Side Step Bar Installed

