

IARMOR EDGE™

PART#: IA-N197

BEFORE INSTALLATION

REMOVE CONTENTS FROM BOX. VERIFY ALL PARTS ARE PRESENT. READ INSTRUCTIONS CAREFULLY BEFORE STARTING INSTALLATION. ASSISTANCE IS RECOMMENDED. THANK YOU FOR CHOOSING OUR PRODUCT!

* **ROCKER PANEL MOUNT**

* **DRILLING/TRIMMING NOT REQUIRED**

Torque Value

Fastener Size	Tightening Torque (ft-lbs)	Required
6mm	6-7	√
8mm	16-18	√
10mm	31-32	X
12mm	56-58	X
14mm	92-94	X

PART LIST

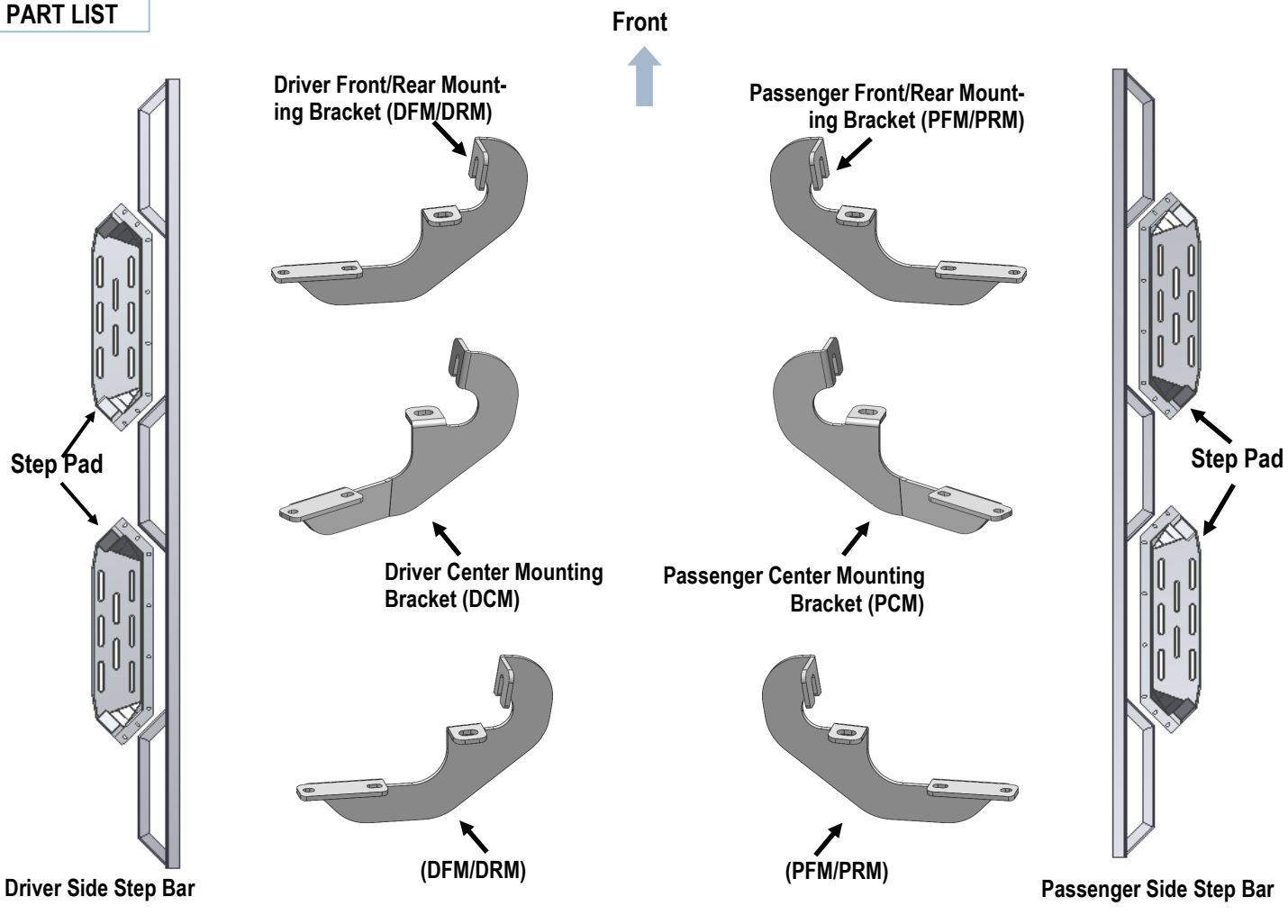

iArmor[®]

Hardware Package					
Item	QTY	Description	Item	QTY	Description
1#	12	M8X1.25-30 Hex Bolts	5#	44	M6X1-20 T- Bolts
2#	12	M8 Large Flat Washers	6#	44	M6 Large Flat Washers
3#	12	M8 Lock Washers	7#	44	M6X1 Nylon Lock Nuts
4#	12	M8 Clip Nuts			

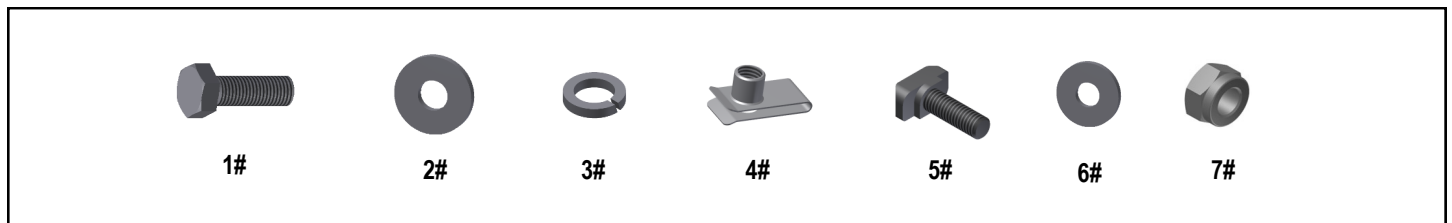

iArmor[®]

The instruction here is for your reference only. We strongly recommend the professional installer for best result. We are not responsible for any damage caused by the installation.

STEP 1

Install the Step Pads onto the step bars with (32) M6X1-20mm T-Bolts, (32) M6 Large Flat Washers and (32) M6X1 Nylon Lock Nuts.

IMPORTANT: Don't hit the step pad with any metal hammer within step pad installation, or the step pad will be damaged.

- (8) M6X1-20 T-Bolts
- (8) M6 Large Flat Washers
- (8) M6 Nylon Lock Nuts

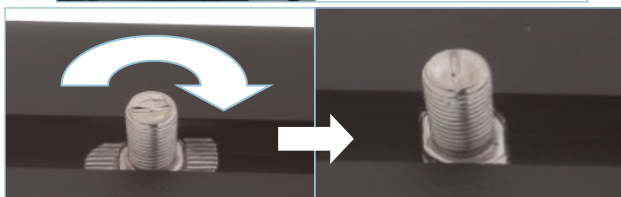

Note: Rotate 90° after inserting the T-Bolts into the Channel!!!

STEP 2

Start the installation from the passenger side of the vehicle. Locate the mounting locations along the bottom and inner side of the body panel, (Fig 1). **NOTE: It will be helpful for identifying the mounting holes to hold up a mounting bracket in place.**

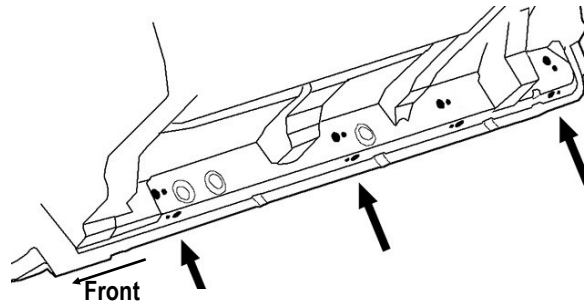

(Fig 1) Passenger Side Mounting Locations

STEP 3

Remove rubber plugs from the Passenger side front location if equipped. Select (2) M8 Clip Nuts. Slide each Clip Nut into the large hole and over the smaller hole next to it. Line up threaded nut on the Clip Nut with smaller hole in body panel, (Fig 2).

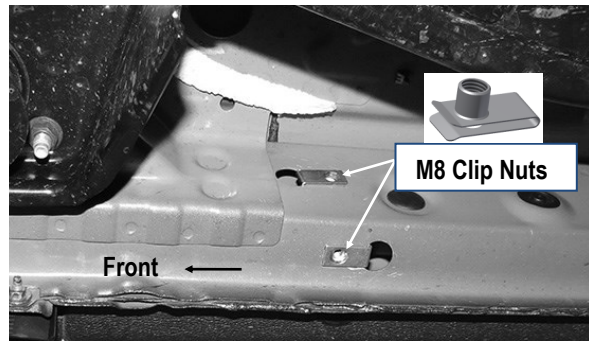

(Fig 2) Passenger Side Front Mounting Location

iArmor®

STEP 4

Select (1) Passenger Front Mounting Bracket (PFM/PRM) . Attach the Bracket to the (2) installed M8 Clip Nuts with (2) M8X1.25-30 Hex Bolts, (2) M8 Lock Washers and (2) M8 Large Flat Washers, (Figs 3 & 4). Do not fully tighten hardware at this time.

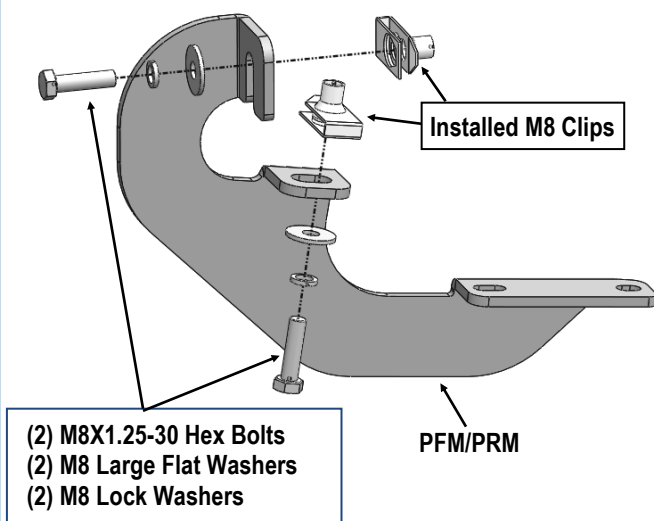

(Fig 3) Passenger Front Mounting Bracket Installation

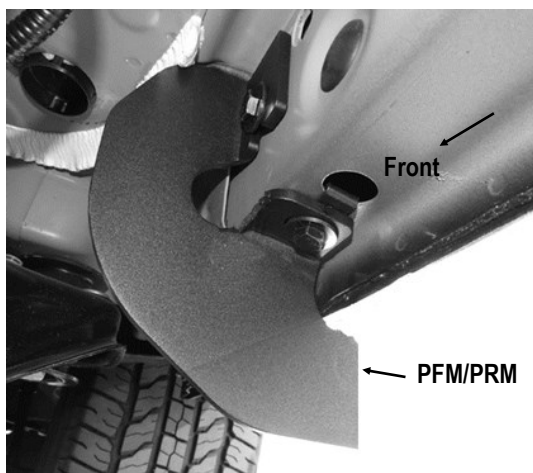

(Fig 4) Passenger Front Mounting Bracket Installed

STEP 5

Move to the Passenger Side Center Mounting location, (Fig 5). Repeat Steps 2—4 to install Passenger Center Mounting Bracket (PCM), (Fig 6). Do not fully tighten hardware at this time.

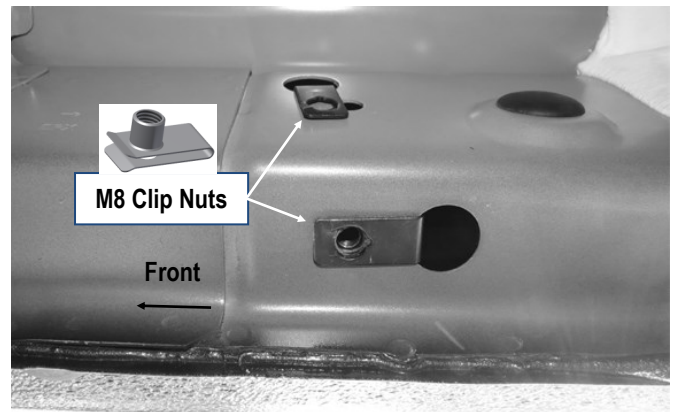

(Fig 5) Passenger Side Center Mounting Location

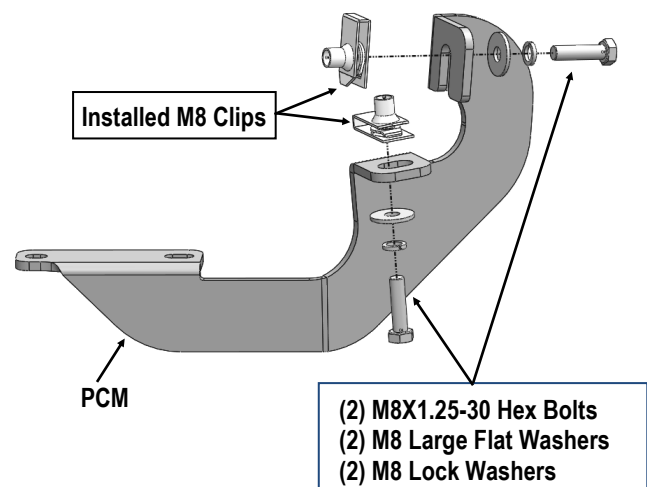

(Fig 6) Passenger Center Mounting Bracket Installation

iArmor®

STEP 6

Move to Passenger Side Rear Mounting location, (Fig 7). Repeat **Steps 2—4** to install the Passenger Rear Mounting Bracket (PFM/PRM), (Fig 8). Do not tighten hardware at this time.

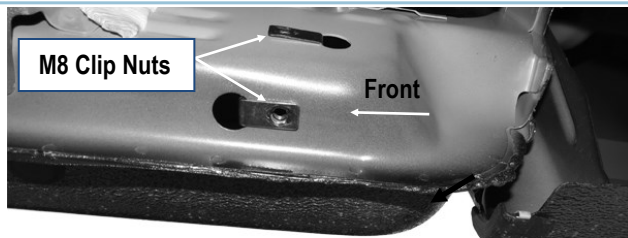

(Fig 7) Passenger Side Rear Mounting Location

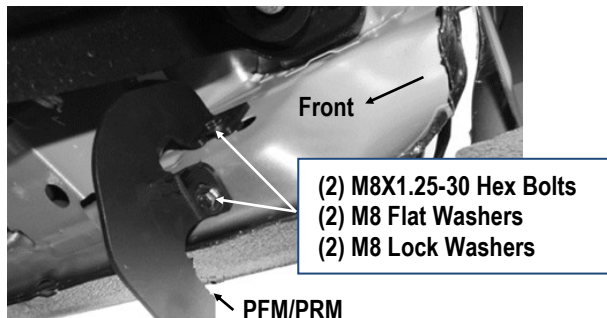

(Fig 8) Passenger Rear Mounting Bracket Installed

STEP 7

Once all (3) Brackets have been installed, attach the Assembled Passenger Side Step Bar to the Mounting Brackets with (6) M6X1-20 T-Bolts, (6) M6 Large Flat Washers & (6) M6X1 Nylon Lock Nuts (Fig 9). Do not tighten hardware at this time. Properly level and adjust the Step Bar and fully tighten all hardware.

STEP 8

Move to the other side of the vehicle. Repeat **Steps 1-7** to install the other side step bar.

Attention

Do periodic inspections to the installation to make sure that all hardware is secure and tight.

In order to protect your bars/boards, please use mild soap/non-abrasive products for cleaning only.

