

IARMOR EDGE™

PART#: IA-N196

BEFORE INSTALLATION

REMOVE CONTENTS FROM BOX. VERIFY ALL PARTS ARE PRESENT. READ INSTRUCTIONS CAREFULLY BEFORE STARTING INSTALLATION. ASSISTANCE IS RECOMMENDED. THANK YOU FOR CHOOSING OUR PRODUCT!

*DRILLING NOT REQUIRED

*TRIMMING MAYBE REQUIRED

Fastener Size	Tightening Torque (ft-lbs)	Required
6mm	6-7	√
8mm	16-18	√
10mm	31-32	X
12mm	56-58	X
14mm	92-94	X

Item	QTY	Description	Item	QTY	Description
1#	2	Driver Front / Passenger Rear Mounting Brackets	6#	8	M8 Lock Washers
2#	1	Driver Rear Mounting Bracket	7#	8	M8 Clip Nuts
3#	1	Passenger Front Mounting Bracket	8#	24	M6X1-20mm T-Bolts
4#	8	M8X1.25-25mm Hex Bolts	9#	24	M6 Large Flat Washers
5#	8	M8 Flat Washers	10#	24	M6X1 Nylon Lock Nuts

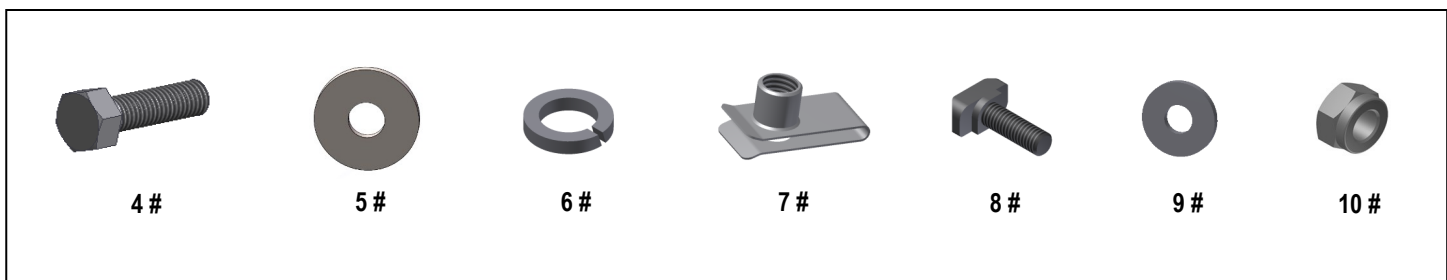

iArmor®

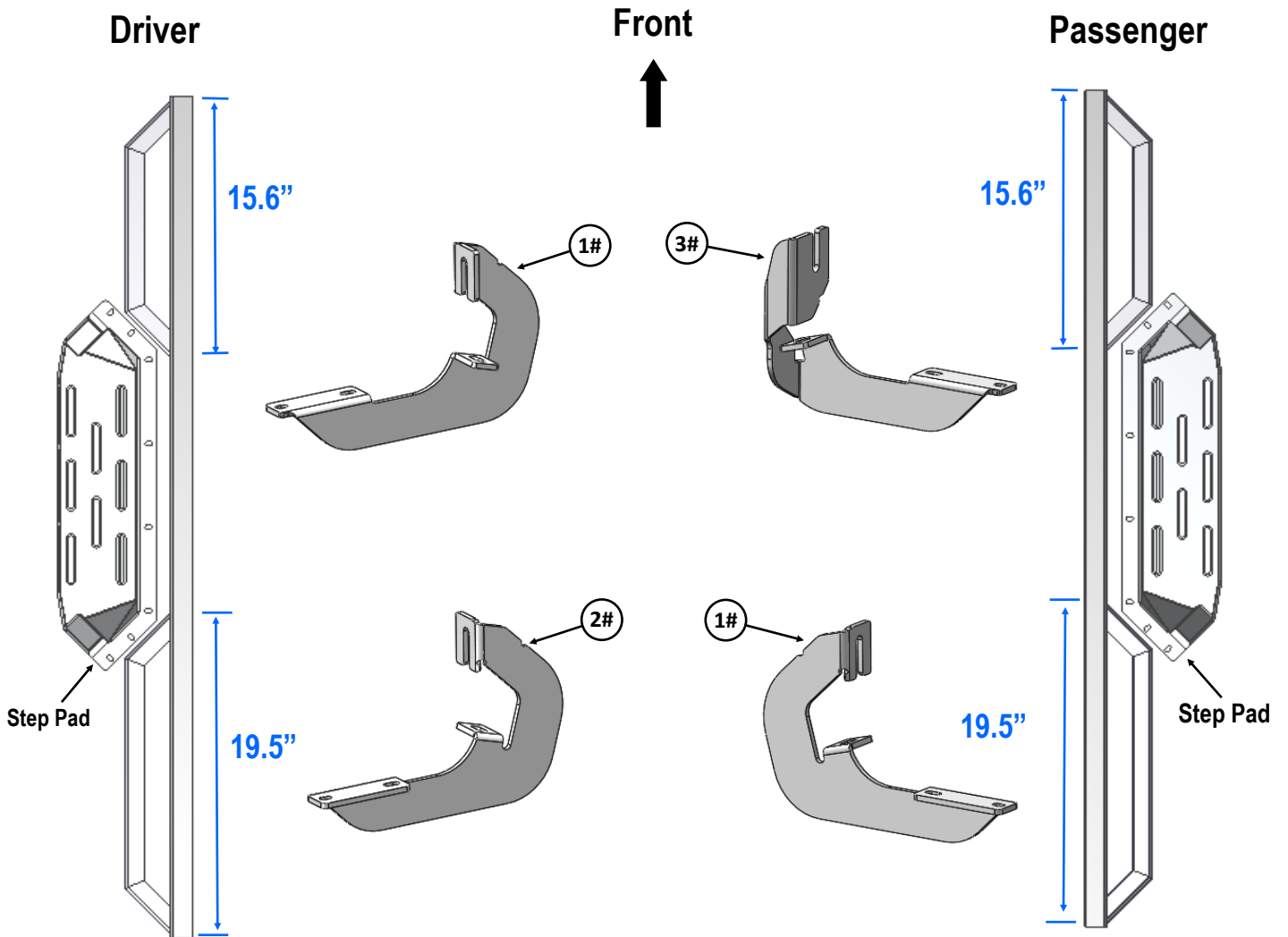

iArmor®

The instruction here is for your reference only. We strongly recommend the professional installer for best result. We are not responsible for any damage caused by the installation.

STEP 1

Install the Step Pads onto the step bars with (16) M6x1-20mm T-Bolts, (16) M6 Flat Washers and (16) M6x1 Nylon Lock Nuts.

IMPORTANT: Don't hit the step pad by any metal hammer within step pad installation, or the step pad will be damaged.

(8) M6X1-20mm T-Bolts
(8) M6 Flat Washers
(8) M6X1 Nylon Lock Nuts

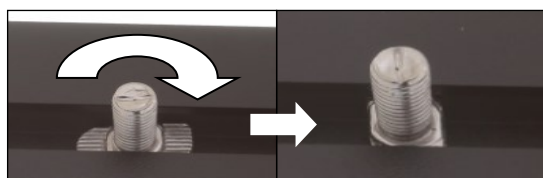
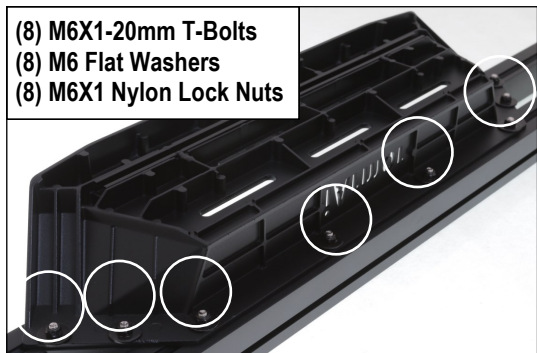

Note: Rotate 90° after inserting the T-Bolts into the Channel!!!

STEP 2

Start the installation from the driver side of the vehicle. Locate the mounting tabs along the bottom edge of the body, (pinch weld). Mounting brackets will bolt to both mounting tabs. Directly above each tab is a top mounting location on the side of the body panel, (Fig 1).

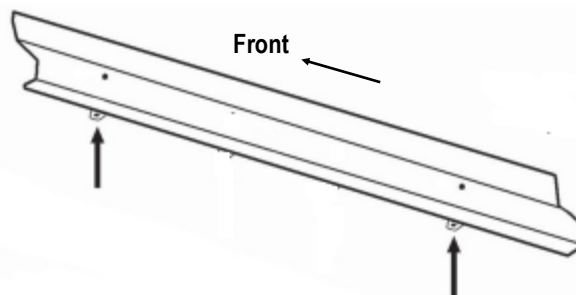

(Fig 1) Driver Side Mounting Locations

STEP 3

Determine the correct procedure for your model year and each Bracket location.

A. Bottom mounting location on the edge of the pinch weld

a) Flat tab on pinch weld with factory installed weld nut: Thread the M8X1.25-25mm Hex Bolt into weld nut from the backside down to clear paint from threads, (Fig 2).

b) Flat tab on pinch weld with hole (Figs 3,4) :

Select (1) M8 Clip Nut. Slide the Clip Nut over the tab with the nut facing up behind the tab. Repeat this **Step** for Driver Rear mounting location.

B. Top mounting location on the inner side of the body panel:

a) Models with factory installed threaded insert in body panel: Thread M8X1.25-25mm Hex Bolt into threaded insert to clear paint as required, (Fig 2).

b) Models with large and small holes on the body panel (Figs 3,4):

Remove the rubber plug from the larger hole. Select (1) M8 Clip Nut. Insert the Clip Nut into the larger hole with the threads facing in.

STEP 4

Select (1) Driver Front Mounting Bracket. Attach bracket to the driver side front mounting location with (2) M8x1.25-25mm Hex Bolts, (2) M8 Lock Washers and (2) M8 Flat Washers, (Figs 5-6). Do not fully tighten hardware at this time.

STEP 4

Select (1) Driver Front Mounting Bracket. Attach bracket to the driver side front mounting location with (2) M8x1.25-25mm Hex Bolts, (2) M8 Lock Washers and (2) M8 Flat Washers, (Figs 5-6). Do not fully tighten hardware at this time.

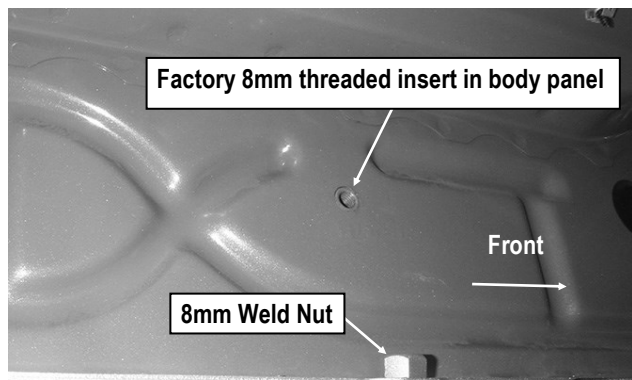

(Fig 2) Flat tab on Pinch Weld with Factory Installed Weld Nut

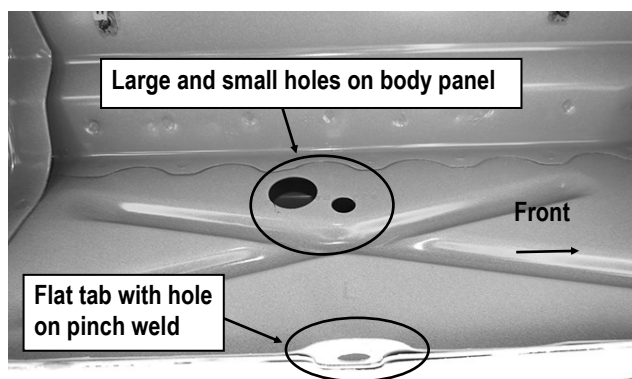

(Fig 3) Driver Side Front Mounting Location
(Flat tab on Pinch Weld with hole)

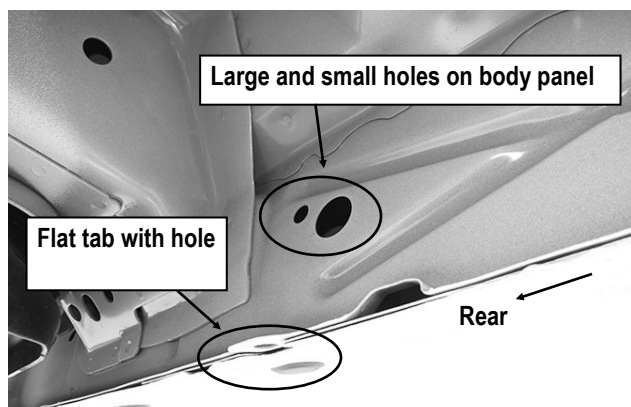

(Fig 4) Driver Side Rear Mounting Location
(Flat tab on Pinch Weld with hole)

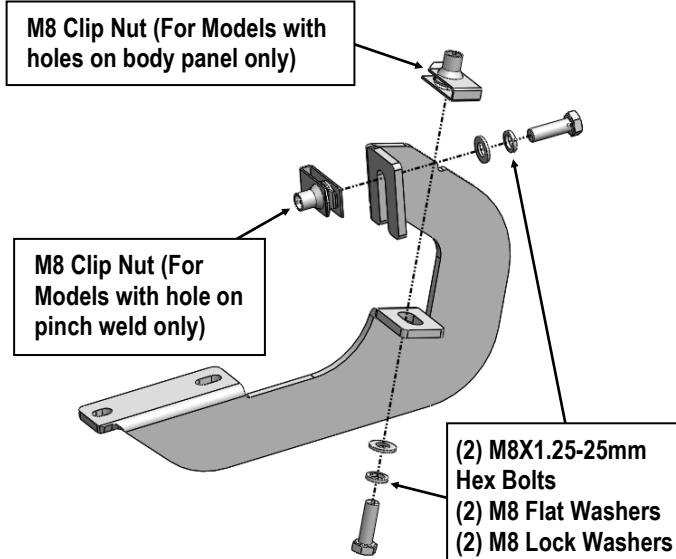

(Fig 5) Driver Front Mounting Bracket Installed

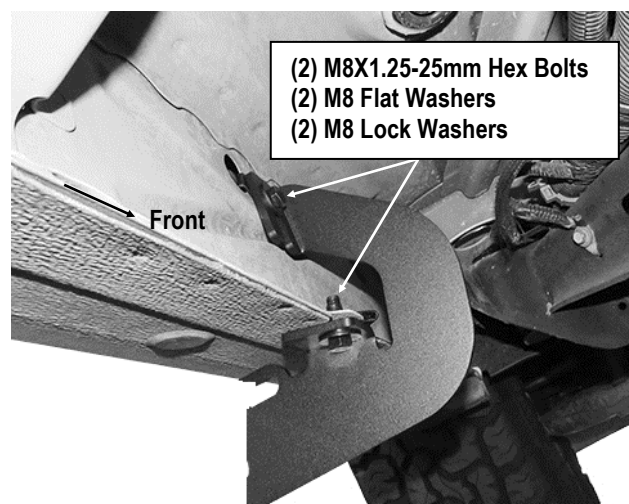

(Fig 6) Driver Front Mounting Bracket Installed

STEP 5

Move to the Driver Side Rear Mounting Location, Repeat **Step 4** to attach Driver Rear Mounting Bracket, (**Fig 7**). Do not fully tighten hardware at this time.

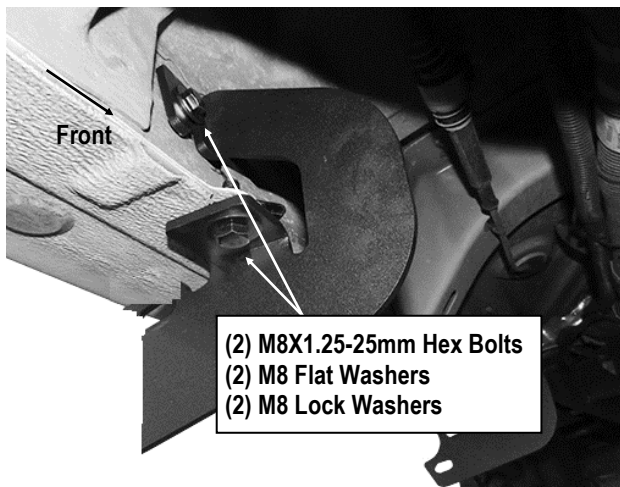

(Fig 7) Driver Rear Mounting Bracket Installed

STEP 6

Once all (2) Brackets have been installed, attach the Assembled Driver Side Step Bar to the Mounting Brackets with (4) M6X1-20mm T-Bolts, (4) M6 Large Flat Washers and (4) M6X1 Nylon Lock Nuts, (**Fig 8**). Do not fully tighten hardware at this time.

STEP 7

Properly level and adjust the Step Bar and fully tighten all hardware.

STEP 8

Move to the passenger side of the vehicle. Determine if the vehicle is equipped with a plastic diesel exhaust fluid (DEF) tank, (**Figs 9 & 10**).

Models without DEF tank skip to Step 9.

Models with DEF tank, first determine correct procedure for your model year:

• **2007-2016 Models with DEF tank:**

The tank sits close to the side of the body. With specialized tools, the Passenger Front Mounting Bracket can be installed but room is limited. It may be easier to drop the tank down to access the inner side of the body panel to mount the bracket. Tank will not need to be removed, only dropped down for access to mounting location.

IMPORTANT: If tank is full, it will be very heavy, and assistance is highly recommended to avoid injury or damage to the vehicle or the tank. It is recommended that installation is performed when the DEF tank is low on fluid before dropping the tank.

- On models with plastic lower tray under the tank, remove the (3) hex bolts attaching the tray to the frame, (**Fig 9**), and remove the tray.
- Release the tank filler hose. Release the plug for the sending unit on the top of the tank.
- Support the tank with a floor jack. Place a smooth flat surface, (wooden block for example), between the floor jack and the tank to avoid damaging the plastic tank. Do not push up on the tank; only support the weight of the tank with the jack.
- Remove the (2) bolts securing the tank straps to the vehicle, (**Fig 10**). Tilt the straps to release from the brackets. Slowly lower the tank until the top of the tank is almost visible. Use blocks or stands to support the tank while installing the Passenger Front Mounting Bracket.
- Proceed to **Step 9**.

• **2017-on 2500/3500 models:**

Do not remove the tank. Remove the (4) hex bolts attaching the plastic cover to DEF tank, (**Fig 11A**) and remove only the plastic cover, (**Fig 11B**).

iArmor®

(Fig 8) Assembled Driver Side step Bar Installed

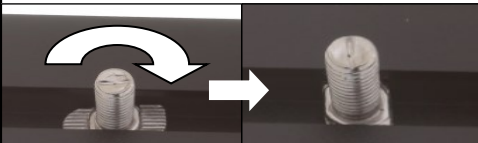
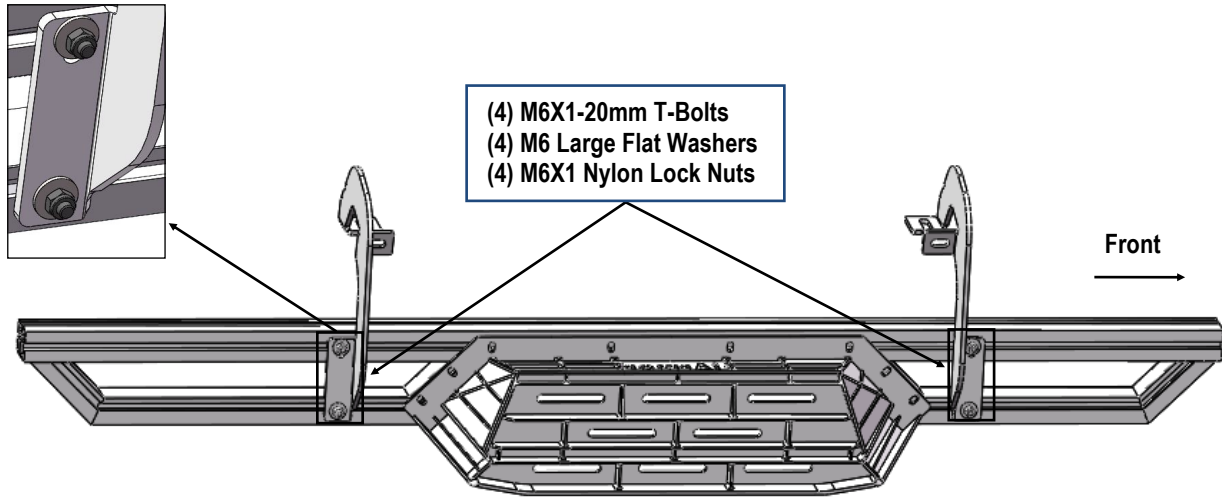

Warning: Install the T-bolt on the step bar and rotate it to 90 degrees!!!

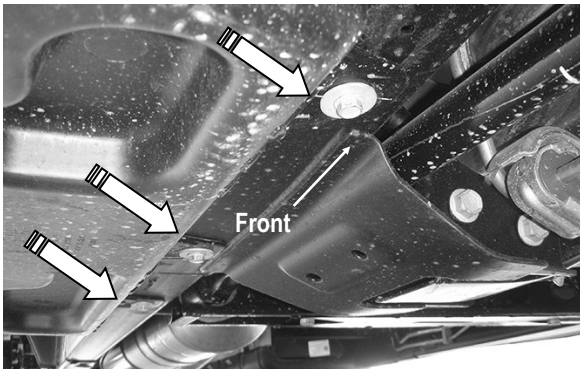

(Fig 9) 07-16 Passenger/Right front pictured with DEF tank cover. Remove (3) hex bolts to remove cover



(Fig 10) Passenger side 07-16 DEF tank and cover

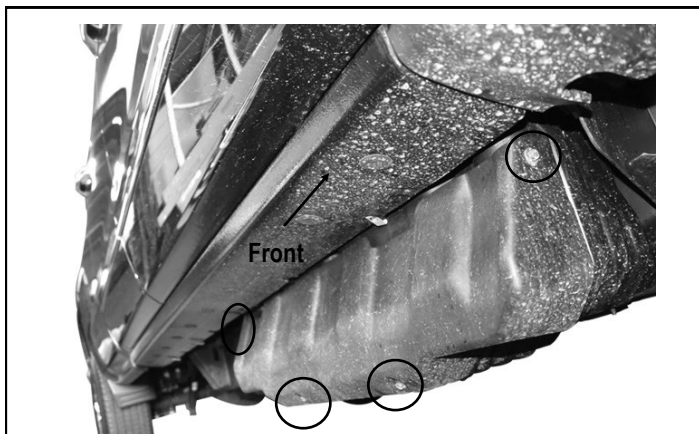

(Fig 11A) 17-on Passenger side pictured with DEF plastic tank cover. Remove (4) hex bolts to remove plastic cover

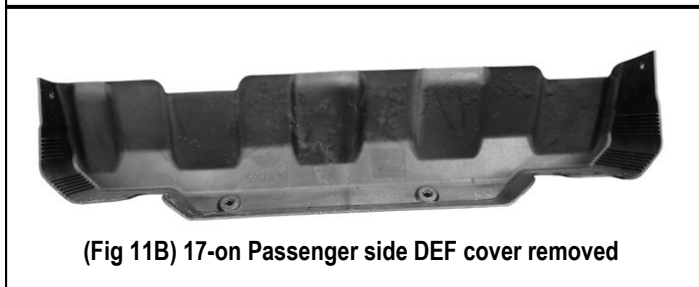

(Fig 11B) 17-on Passenger side DEF cover removed

STEP 9

Locate the front tab on the edge of the pinch weld on the Passenger/Right side. Repeat **Step 3** to attach M8 Clip Nuts to the body panel.

STEP 10

Select the Passenger Front Mounting Bracket:

Secure the mounting bracket to the body panel:

a. For models with threaded insert in body panel:

Attach the mounting bracket to the body panel with (1) M8X1.25-25mm Hex Bolt, (1) M8 Lock Washer and (1) M8 Flat Washer, (Fig 12).

b. For models with holes in the body panel:

Attach the mounting bracket to the body panel with (1) M8X1.25-25mm Hex Bolt, (1) M8 Lock Washer, (1) M8 Flat Washer and (1) M8 Clip Nut, (Fig 12).

Secure the mounting bracket to the pinch weld:

a. For models with a weld nut on the Pinch Weld:

Attach the mounting bracket to the pinch weld with (1) M8x1.25 - 25mm Hex Bolt, (1) M8 Lock Washer and (1) M8 Flat Washer, (Fig 12).

b. For models with flat tab and hole in the Pinch Weld:

Attach the mounting bracket to the pinch weld with (1) M8x1.25 - 25mm Hex Bolt, (1) M8 Lock Washer, (1) M8 Flat Washer and (1) M8 Clip Nut, (Fig 12).

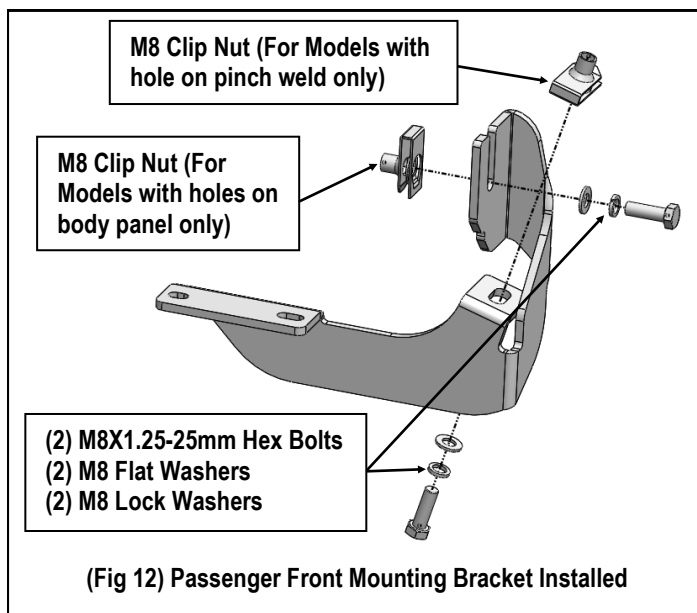

(Fig 12) Passenger Front Mounting Bracket Installed

STEP 11

Repeat **Steps 3-4** to attach the Passenger Rear Mounting Bracket to the Passenger/Right side rear mounting location. Do not fully tighten hardware at this time.

STEP 12

2017-on 2500/3500 DEF tank models:

Locate the passenger side rear mounting location along the bottom edge of the body, (pinch weld). Hold the DEF cover in place and mark the rear bracket location onto the cover, (Fig 13). Use a sharp knife or hacksaw blade to carefully cut a slot in the plastic cover to clear the Passenger Rear Mounting Bracket, (Fig 14). Remove as little plastic as possible.

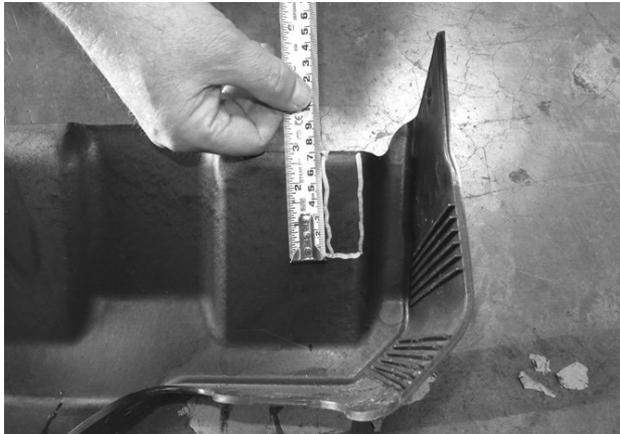

mark pictured is approximately 70mm x 10mm

(Fig 13) 17-on Passenger DEF cover marked for trimming

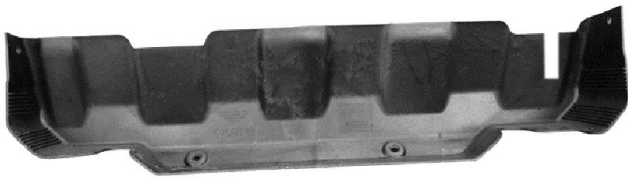

(Fig 14) 17-on Passenger DEF cover cut for example only

STEP 13

Once all (2) Brackets have been installed, repeat Step 6 to install the Assembled Passenger Side Step Bar to the Mounting Brackets with (4) M6X1-20mm T-Bolts, (4) M6 Large Flat Washers and (4) M6X1 Nylon Lock Nuts. Do not fully tighten hardware at this time.

STEP 14

Properly level and adjust the Step Bar and fully tighten all hardware. Installation is completed!!!

Attention

Do periodic inspections to the installation to make sure that all hardware is secure and tight.

In order to protect your bars/boards, please use only mild soap/non-abrasive products for cleaning.