

# iArmor®

## IARMOR EDGE™

PART#: IA-N171H

### BEFORE INSTALLATION

REMOVE CONTENTS FROM BOX. VERIFY ALL PARTS ARE PRESENT. READ INSTRUCTIONS CAREFULLY BEFORE STARTING INSTALLATION. ASSISTANCE IS RECOMMENDED. THANK YOU FOR CHOOSING OUR PRODUCT!

\*ROCKER PANEL MOUNT

\*DRILLING/TRIMMING NOT REQUIRED

### Torque Value

| Fastener Size | Tightening Torque (ft-lbs) | Required |
|---------------|----------------------------|----------|
| 6mm           | 6-7                        | √        |
| 8mm           | 16-18                      | √        |
| 10mm          | 31-32                      | X        |
| 12mm          | 56-58                      | X        |
| 14mm          | 92-94                      | X        |

### PART LIST

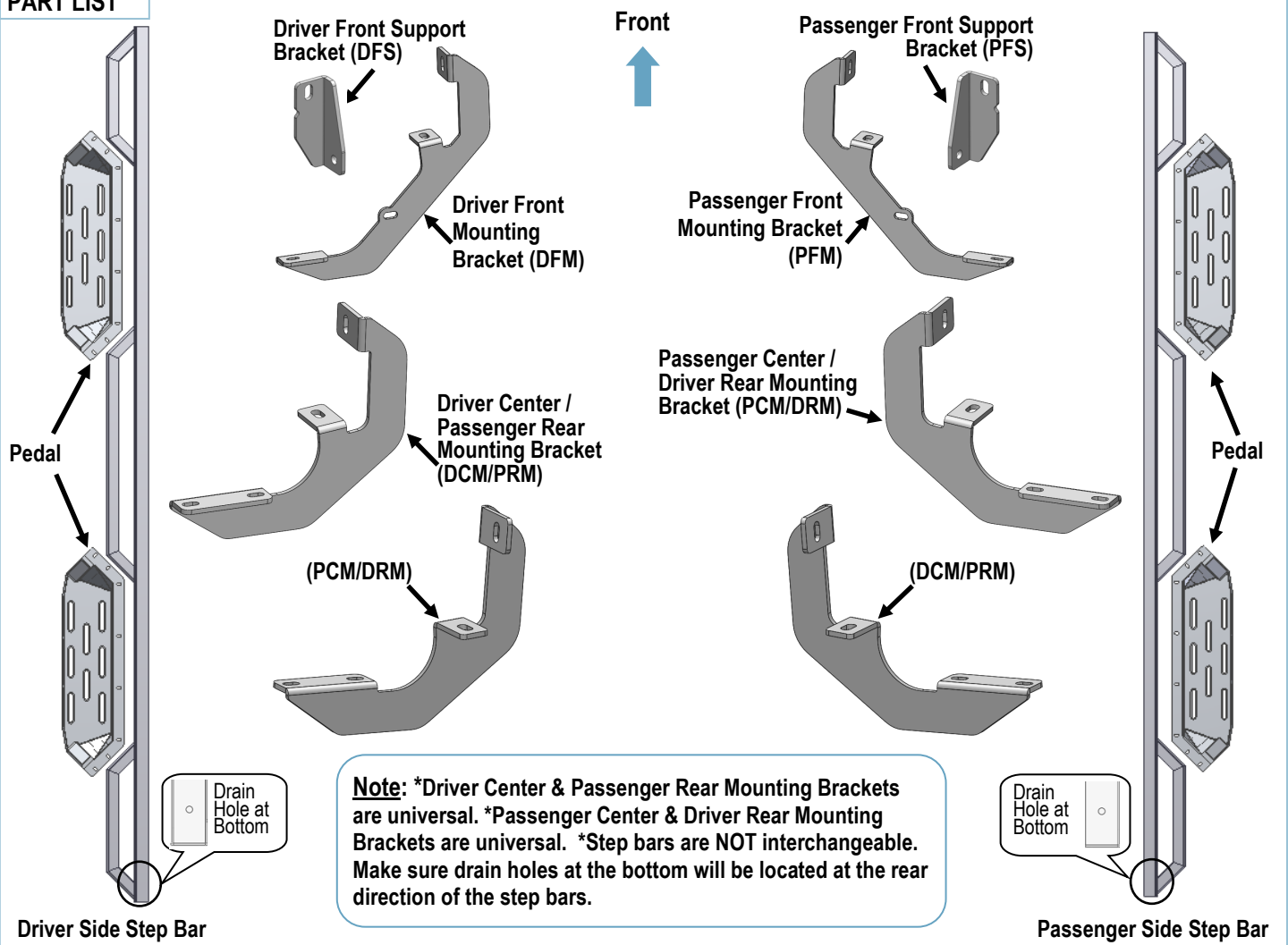

Customer Support: [info@iarmorauto.com](mailto:info@iarmorauto.com)

# iArmor<sup>®</sup>

| Hardware Package A (For Brackets & Bars Installation) |     |                           |      |     |                       |
|---|-----|---------------------------|------|-----|-----------------------|
| Item  | QTY | Description               | Item | QTY | Description           |
| 1#  | 14  | M8X1.25-30 Hex Bolts      | 6#   | 2   | M6 Large Flat Washers |
| 2#  | 26  | M8 Large Flat Washers     | 7#   | 2   | M6X1 Nylon Lock Nuts  |
| 3#  | 12  | M8 Lock Washers           | 8#   | 10  | M8X1.25-20 T- Bolts   |
| 4#  | 12  | M8X1.25 Nylon Lock Nuts   | 9#   | 10  | M8 Plastic Washers    |
| 5#  | 2   | M6X1-20 Square Head Bolts |      |     |                       |

1#                      2#                      3#                      4#                      5#

6#                      7#                      8#                      9#

| Hardware Package B (For Step Pedals Installation) |     |                       |      |     |                 |
|---|-----|-----------------------|------|-----|-----------------|
| Item  | QTY | Description           | Item | QTY | Description     |
| 1#  | 24  | M8X1.25-25 Hex Bolts  | 3#   | 24  | M8 Lock Washers |
| 2#  | 24  | M8 Large Flat Washers |      |     |                 |

1#                      2#                      3#

# iArmor®

The instruction here is for your reference only. We strongly recommend the professional installer for best result. We are not responsible for any damage caused by the installation.

## STEP 1

Install (4) Pedals onto the step bars with (24) M8X1.25-25mm Hex Bolts, (24) M8 Large Flat Washers and (24) M8 Lock Washers.

**IMPORTANT:** Don't punch the pedal with any metal hammer within pedal installation, or the pedal will be damaged.

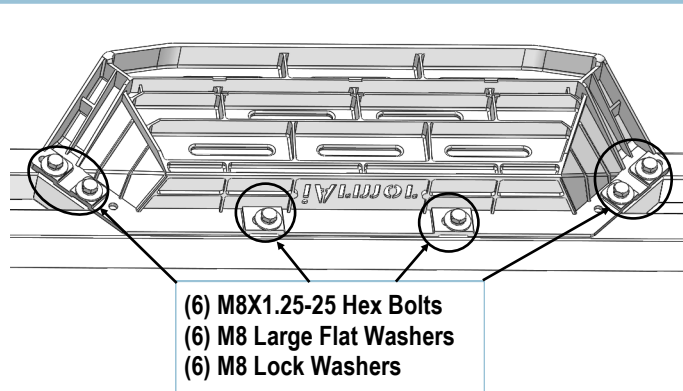

## STEP 2

Start the installation under the passenger side of the vehicle. Locate the 6 plugs along the bottom of the body panel. Remove the plastic plugs from each mounting location if equipped. Mounting Brackets will bolt to the 1st, 3rd and 6th threaded mounting holes, (Figs 1-4).

Directly above each threaded insert is a top mounting location on the side of the body panel.

**NOTE:** Thread an 8mm Hex Bolt into the threaded inserts to clear paint as required.

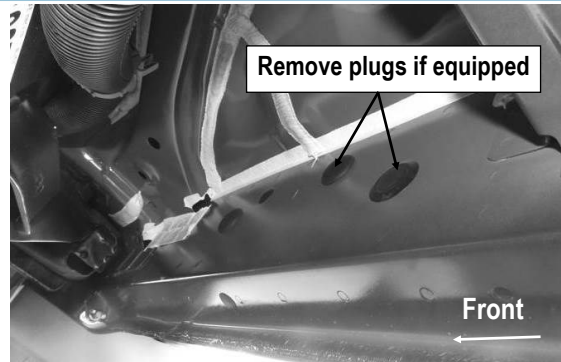

(Fig 1) Remove Plastic Plugs to Uncover Threaded Inserts

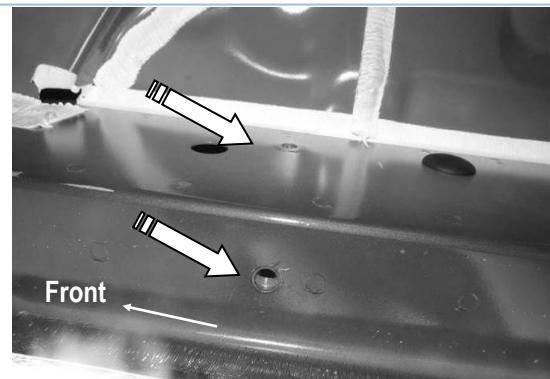

(Fig 2) Passenger Front Mounting Location

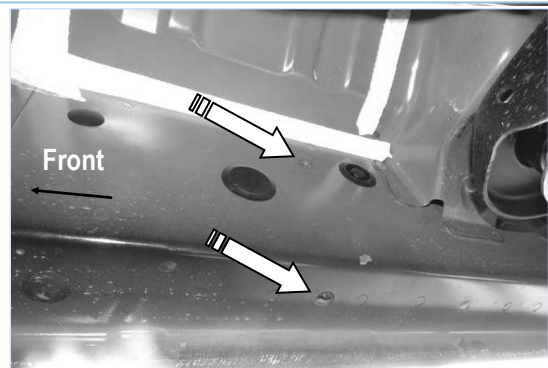

(Fig 3) Passenger Center Mounting Location

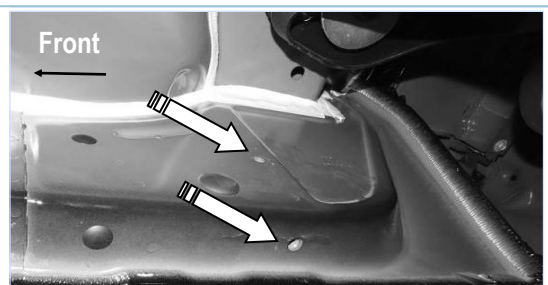

(Fig 4) Passenger Rear Mounting Location

# iArmor<sup>®</sup>

## STEP 3

Assemble Passenger Front Mounting Bracket (PFM) and Passenger Front Support Bracket (PFS) with (1) M8X1.25-30mm Hex Bolt, (2) M8 Large Flat Washers and (1) M8 Nylon Lock Nut, (Fig 5). Do not fully tighten at this time.

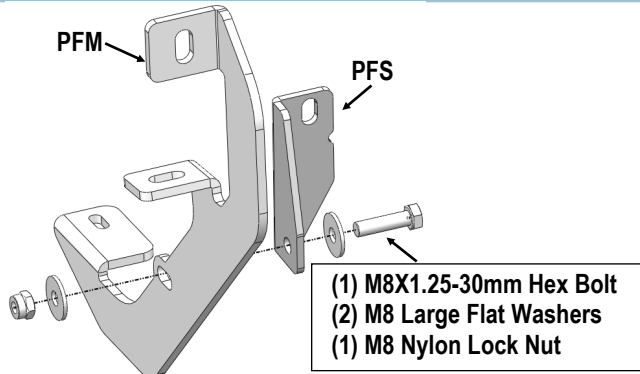

(Fig 5) Passenger Front Mounting Bracket Assembly

## STEP 4

Attach the Assembled Passenger Front Mounting Bracket to the factory threaded holes with (2) M8 X1.25-30mm Hex Bolts, (2) M8 Lock Washers and (2) M8 Large Flat Washers, (Fig 6). Do not fully tighten hardware at this time.

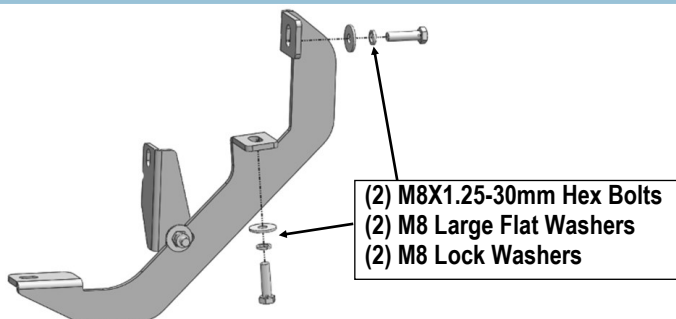

(Fig 6) Passenger Front Mounting Bracket Installation

## STEP 5

Repeat Steps 3 & 4 to install Passenger Center Mounting Bracket (PCM/DRM) and Passenger Rear Mounting Bracket (DCM/PRM) on the remaining mounting locations. (Figs 7-8).

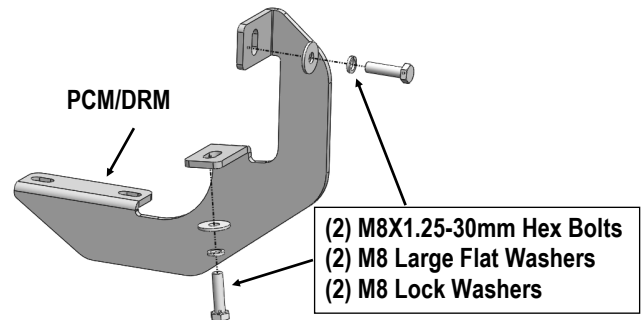

(Fig 7) Passenger Center Mounting Bracket Installation

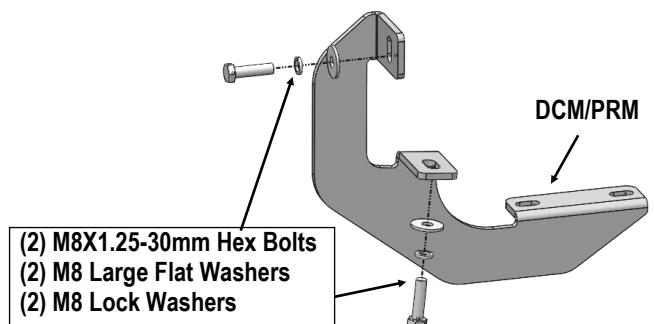

(Fig 8) Passenger Rear Mounting Bracket Installation

## STEP 6

Once (3) brackets have been installed, select (5) M8X1.25-20mm T-Bolts, thread (1) M8 Plastic Washer on each T-Bolt, (Fig 9). Install the (5) M8X1.25-20mm T-Bolts with plastic washers in the slots on the assembled passenger side step bar. Rotate the T-Bolts to 90 degree, thread down the M8 Plastic Washers against the step bar (Fig 10).

**NOTE:** The Plastic Washer is designed to keep the T-Bolt in place to avoid falling into the tube during installation.

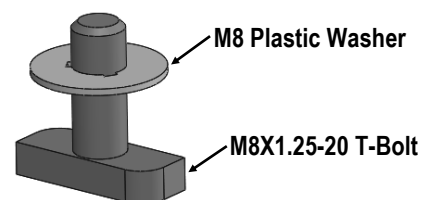

(Fig 9) Thread (1) M8 Plastic Washer on each T-Bolt Before Inserting into the slot !!!

# iArmor®

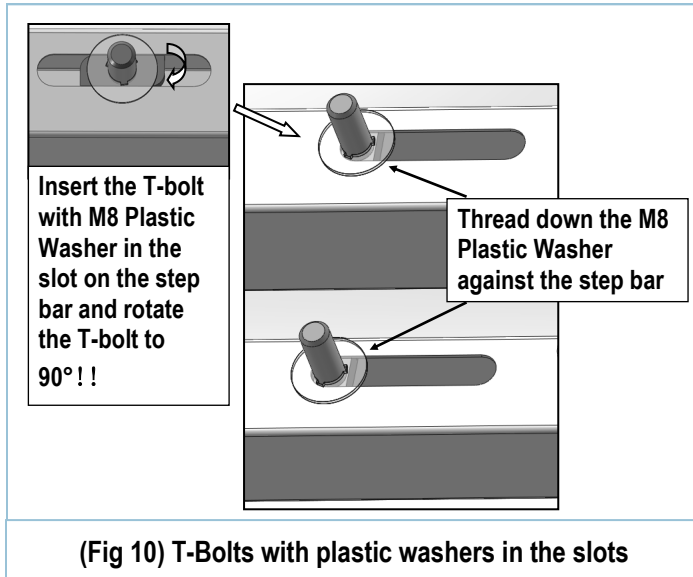

## STEP 8

Level and adjust the assembled Step Bar properly and tighten all hardware.

Move to the other side of the vehicle. Repeat **Steps 2-7** for the other side step bar installation.

### Attention

**Do periodic inspections to the installation to make sure that all hardware is secure and tight.**

**In order to protect your bars/boards, please use mild soap/non-abrasive products for cleaning only.**

## STEP 7

Attach the Assembled Passenger Side Step Bar onto the Mounting Brackets with (5) M8 Plastic Washers, (5) M8X1.25-20mm T-Bolts, (5) M8 Large Flat Washers, (5) M8 Nylon Lock Nuts, (**Fig 11**). Do not fully tighten hardware at this time.

**NOTE:** the Passenger Front Mounting Bracket is located under the front pedal. Slide (1) M6X1-20mm Square Head Bolt into the channel at the bottom of the front pedal (**Fig 12**). And secure the Passenger Front Mounting Bracket to the pedal with (1) M6 Large Flat Washer and (1) M6 Nylon Lock Nut, (**Fig 11**).

# iArmor<sup>®</sup>

(Fig 11) Passenger Side Step Installation

