

Part#	HT-R30595	Application	For 2010-2013 Subaru Outback 2015-2019 Subaru Legacy					
-------	-----------	-------------	--------------------------------------------------------	--	--	--	--	--

Hardware List	Item	Part Name	QTY	Description	Item	Part Name	QTY	Description
	1	Carriage Bolts	4	M12X1.75-40	3	Hex Flange Nuts	4	M12X1.75
2	Spacers	4	With SQ Hole	4	Fishwires	2		

Gross Load Capacity When Used As A Weight Carrying Hitch: 4000 LBS. Trailer Weight & 600 LBS. Tongue Weight.
*****DO NOT EXCEED VEHICLE MANUFACTURER'S RECOMMENDED TOWING CAPACITY.*****

- * Trimming Required
- * Drilling Required

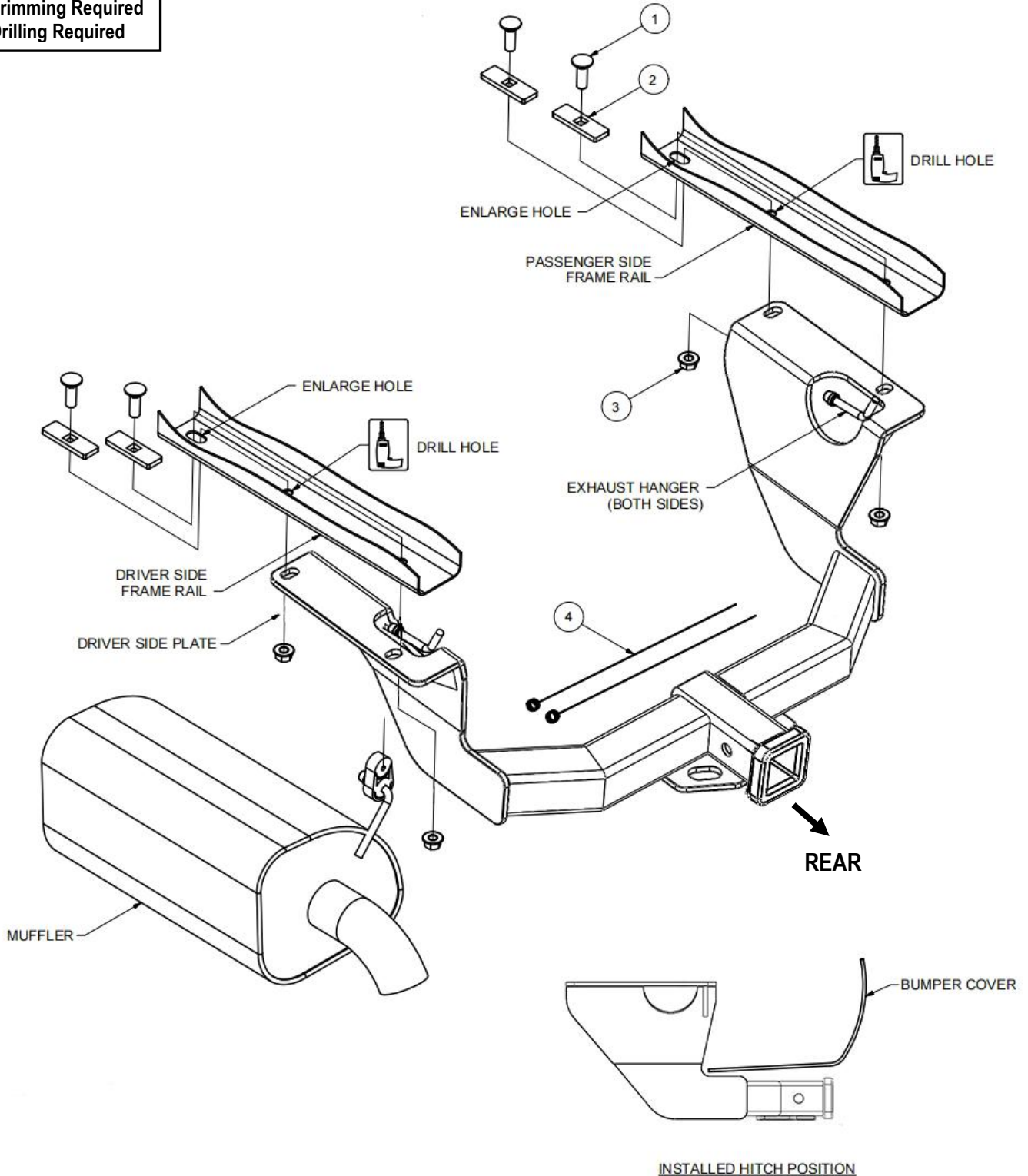

The instruction here is for your reference only. We strongly recommend the professional installer for best result. We are not responsible for any damage caused by the installation. Thank you for choosing our product!

Part#	HT-R30595	Application	For 2010-2013 Subaru Outback 2015-2019 Subaru Legacy
-------	-----------	-------------	--------------------------------------------------------

RUBBER ISOLATOR REMOVAL DIAGRAM

This technique can be used if exhaust hanger removal pliers are not available.

Using a 5/8" open end wrench, slide the wrench up to the rubber isolator, cradling the hanger rod as shown.

Place the flat edge of a pry bar between the wrench and the hanger stop or hanger rod. Then simply rotate the pry bar toward the wrench to remove the rubber isolator.

Note: Using a lubricant or soapy water on the hanger rod and the rubber isolator helps removal.

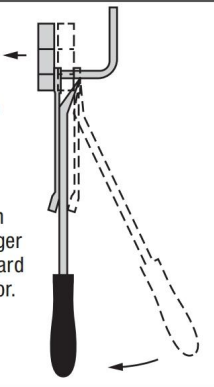

FISHWIRE TECHNIQUE

INSERT COILED END OF FISHWIRE TOOL THROUGH HITCH MOUNTING HOLE IN VEHICLE FRAME RAIL AND OUT THE ACCESS HOLE. PASS COILED END OF FISHWIRE THROUGH SPACER AND THREAD BOLT INTO COIL. KINK WIRE TO KEEP SPACER SEPERATE FROM BOLT AS SHOWN. PULL FISHWIRE, SPACER, AND BOLT THROUGH FRAME AND OUT MOUNTING HOLE. USE FISHWIRE TO GUIDE HITCH DURING MOUNTING AND PREVENT LOSS OF BOLT / SPACER INSIDE FRAME RAIL.

****NOTE: SOME VEHICLES MAY FISHWIRE THROUGH END OF FRAME****

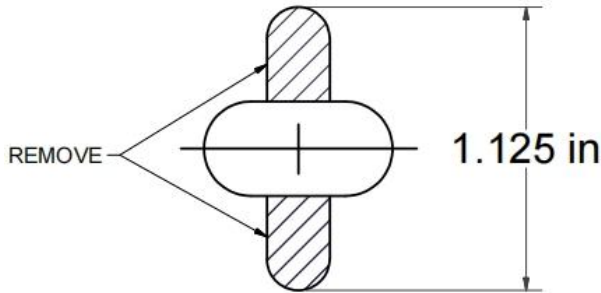
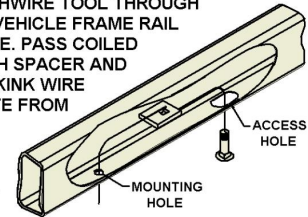

HOLE ENLARGEMENT DIAGRAM



HEAT SHIELD TRIM DIAGRAM

Step	Description
1	Lower the exhaust by removing the (3) rearmost rubber exhaust isolators from the frame mounted hangers. Note: Support the exhaust during installation to prevent damage. (See Rubber Isolator Removal Diagram.)
2	Remove the muffler heat shield and trim to clear the mounting plate. (See Heat Shield Trim Diagram.)
3	Remove the (2) rubber plugs in each frame rail. Enlarge the forwardmost hole on each frame rail to allow the carriage bolt and spacer to be inserted into the frame rail. (See Hole Enlargement Diagram.)
4	Fishwire a carriage bolt and spacer into the rearmost hole in each frame rail as shown. (See Fishwire Hardware Technique.)
5	Raise the hitch into position, taking care not to push the fishwired hardware into the frame rails. Center the hitch on the vehicle and loosely secure the hitch to the vehicle with hex flange nuts as shown.
6	Mark and drill the forwardmost holes in the frame rail using the hitch as your template.
7	Fishwire a carriage bolt and spacer into each drilled hole and secure the hitch with a hex flange nut as shown.
8	Torque all hardware to 86 ft-lbs.
9	Reinstall the heat shield, raise the exhaust and reinstall the rubber isolators.

*****Periodically Check The Receiver Hitch To Ensure That All Fasteners ***
Are Tight & All Structural Components Are Sound.**

The instruction here is for your reference only. We strongly recommend the professional installer for best result. We are not responsible for any damage caused by the installation. Thank you for choosing our product!