

Part#	HT-R30234	Application	For 2015-2024 Ford Edge					
-------	-----------	-------------	-------------------------	--	--	--	--	--

Hardware List	Item	Part Name	QTY	Description	Item	Part Name	QTY	Description
	1	Carriage Bolts	6	M12X1.75-40	3	Hex Flange Nuts	6	M12X1.75
	2	Spacers	6	With SQ Hole	4	Fishwires	4	

Gross Load Capacity When Used As A Weight Carrying Hitch: 4000 LBS. Trailer Weight & 600 LBS. Tongue Weight.
*****DO NOT EXCEED VEHICLE MANUFACTURER'S RECOMMENDED TOWING CAPACITY.*****

- * Trimming Required
- * No Drilling Required

RUBBER ISOLATOR REMOVAL DIAGRAM

This technique can be used if exhaust hanger removal pliers are not available.

Using a 5/8" open end wrench, slide the wrench up to the rubber isolator, cradling the hanger rod as shown.

Place the flat edge of a pry bar between the wrench and the hanger stop or hanger rod. Then simply rotate the pry bar toward the wrench to remove the rubber isolator.

Note: Using a lubricant or soapy water on the hanger rod and the rubber isolator helps removal.

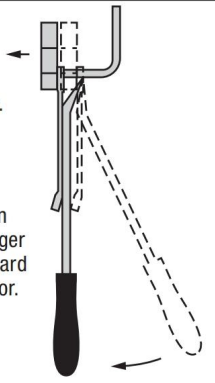

FISHWIRE TECHNIQUE

INSERT COILED END OF FISHWIRE TOOL THROUGH HITCH MOUNTING HOLE IN VEHICLE FRAME RAIL AND OUT THE ACCESS HOLE. PASS COILED END OF FISHWIRE THROUGH SPACER AND THREAD BOLT INTO COIL. KINK WIRE TO KEEP SPACER SEPERATE FROM BOLT AS SHOWN. PULL FISHWIRE, SPACER, AND BOLT THROUGH FRAME AND OUT MOUNTING HOLE. USE FISHWIRE TO GUIDE HITCH DURING MOUNTING AND PREVENT LOSS OF BOLT / SPACER INSIDE FRAME RAIL.

NOTE: SOME VEHICLES MAY FISHWIRE THROUGH END OF FRAME

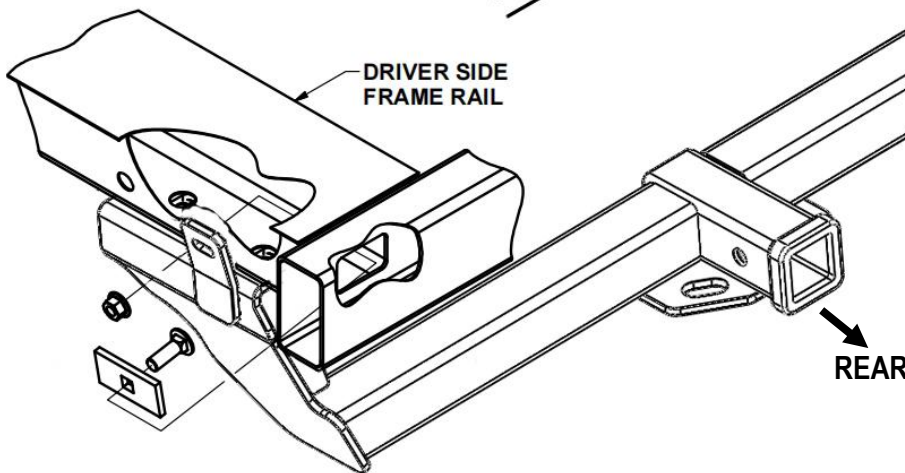
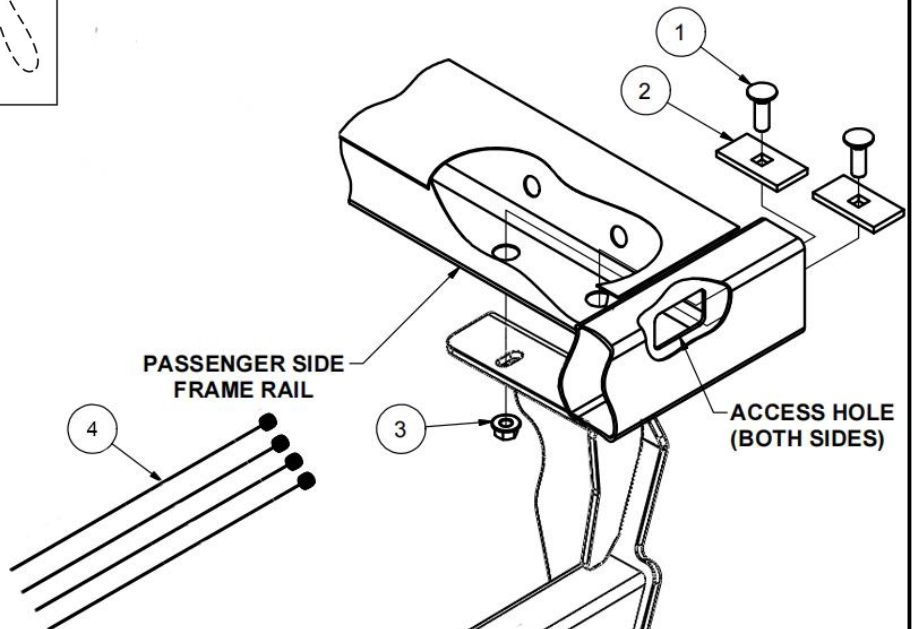
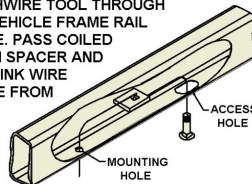

The instruction here is for your reference only. We strongly recommend the professional installer for best result. We are not responsible for any damage caused by the installation. Thank you for choosing our product!

Part#	HT-R30234	Application	For 2015-2024 Ford Edge
-------	-----------	-------------	-------------------------

Step	Description
1	Support and lower the exhaust by removing (2) rubber isolators mounted to the muffler. Note: Sport model will require the removal of the exhaust bezels using a 5.5mm socket and a T20 Torx bit. Remove the panels from behind the rear wheels by removing (2) hex nuts using a 10mm socket and (2) screws with a 7/32" socket. Set panels aside for later installation.
2	Fishwire (3) spacers and (3) carriage bolts into the mounting holes as shown for both frames.
3	Trim the center under body panel outer tabs to allow easier mounting of the hitch. Trim the removed underbody side panels as shown in the diagram above to allow for reinstallation.
4	Raise hitch over exhaust and thread fishwires into the mounting holes. Raise hitch into mounting position, remove the fishwires and install (6) hex flange nuts.
Note: The hitch side plates will be located between the center underbody panel tabs and the frame rails.	
5	Torque all M12 fasteners to 86 lb-ft. Reinstall the trimmed underbody panels onto the vehicle using the hardware removed in step 1. Note: The washer/nut may require trimming of the washer for reinstallation.
6	Raise the exhaust back into position and reinstall rubber isolators and exhaust bezels if removed.
Note: On vehicles equipped with hands free lift gate, perform the kick motion on the left or right side of the receiver tube.	
***Periodically Check The Receiver Hitch To Ensure That All Fasteners *** Are Tight & All Structural Components Are Sound.	

The instruction here is for your reference only. We strongly recommend the professional installer for best result. We are not responsible for any damage caused by the installation. Thank you for choosing our product!