

Part#	HT-R30152	Application	For 2013-2018 Hyundai Santa Fe Sport \2014-2015 Kia Sorento					
-------	-----------	-------------	---	--	--	--	--	--

Hardware List	Item	Part Name	QTY	Description	Item	Part Name	QTY	Description
	1	Carriage Bolts	4	M12X1.75-120	4	Conical Washers	4	M10
	2	Hex Flange Nuts	4	M12X1.75	5	Spacer Plate	1	
	3	Hex Bolts	4	M10X1.25-25				

Gross Load Capacity When Used As A Weight Carrying Hitch: 6000 LBS. Trailer Weight & 900 LBS. Tongue Weight.  
 Gross Load Capacity When Used As A Weight Distribution Hitch: 8000 LBS. Trailer Weight & 900 LBS. Tongue Weight  
**\*\*\*DO NOT EXCEED VEHICLE MANUFACTURER'S RECOMMENDED TOWING CAPACITY.\*\*\***

**\*Trimming May Be Required**  
**\* No Drilling Required**

**WELDNUT CLEANING**

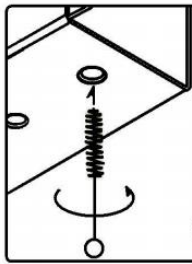

To remove debris from weldnuts in frame, spray lubricant or compressed air into hole. For heavy debris, use a small wire brush. (Be careful not to damage threads).

**CONICAL TOOTHED WASHER ORIENTATION DIAGRAM**

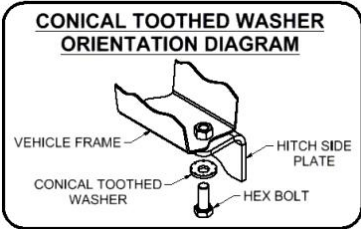

VEHICLE FRAME — HITCH SIDE PLATE  
 CONICAL TOOTHED WASHER — HEX BOLT

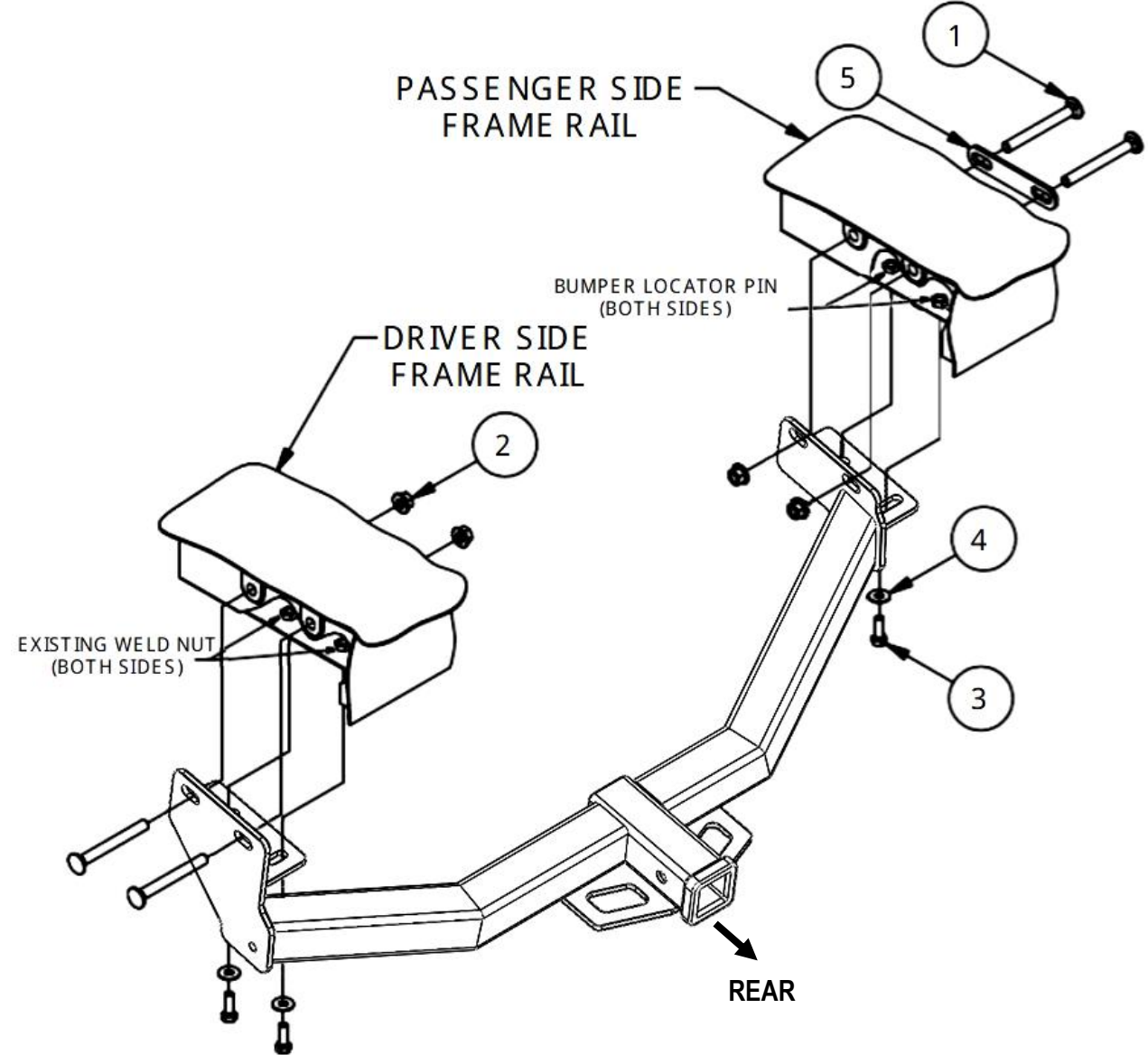

The instruction here is for your reference only. We strongly recommend the professional installer for best result. We are not responsible for any damage caused by the installation. Thank you for choosing our product!

Part#	HT-R30152	Application	For 2013-2018 Hyundai Santa Fe Sport \2014-2015 Kia Sorento
-------	-----------	-------------	---

Step	Description
------	-------------

1	Lower and remove spare tire.
---	------------------------------



2	Lower exhaust by removing (3) rubber isolators.
---	---

**RUBBER ISOLATOR REMOVAL DIAGRAM**

This technique can be used if exhaust hanger removal pliers are not available. Using a 5/8" open end wrench, slide the wrench up to the rubber isolator, cradling the hanger rod as shown.

Place the flat edge of a pry bar between the wrench and the hanger stop or hanger rod. Then simply rotate the pry bar toward the wrench to remove the rubber isolator.

**Note:** Using a lubricant or soapy water on the hanger rod and the rubber isolator helps removal.



3	Remove the plastic under body panel from the passenger side and the driver side frame rails. Remove (3) fascia screws from the passenger side and (4) from the driver side. Carefully pull down and set aside.
---	--



4	Raise hitch into position and secure to the existing weldnuts with M10-1.25 x 25mm bolts and conical toothed washers. Note: The bumper locator pin may interfere with the hitch hardware. You may need to bend or trim it to allow hardware clearance.
---	--



The instruction here is for your reference only. We strongly recommend the professional installer for best result. We are not responsible for any damage caused by the installation. Thank you for choosing our product!

Part#	HT-R30152	Application	For 2013-2018 Hyundai Santa Fe Sport \2014-2015 Kia Sorento
-------	-----------	-------------	---

5	Insert carriage bolts through the driver side plate and frame rail, secure using flange nuts. Insert carriage bolts through the spacer, in the passenger side frame rail and out the passenger side plate, secure using flange nuts.
---	--



6	Torque all M12 hardware to 86 ft-lbs. Torque all M10 hardware to 48 ft-lbs. Raise exhaust and spare tire back into position. Reinstall passenger side and driver side under body panels removed in Step (3).
---	--

**\*\*\*Periodically Check The Receiver Hitch To Ensure That All Fasteners \*\*\*  
Are Tight & All Structural Components Are Sound.**

The instruction here is for your reference only. We strongly recommend the professional installer for best result. We are not responsible for any damage caused by the installation. Thank you for choosing our product!