

Part#	HT-R39511	Application	For 1997-2001 Honda CR-V				
-------	-----------	-------------	--------------------------	--	--	--	--

Hardware List	Item	Part Name	QTY	Description	Item	Part Name	QTY	Description
	1	Hex Flange Nuts	6	M10X1.5	4	Carriage Bolts	2	M10X1.5-45
	2	Spacers	4	With SQ Hole	5	U-Bolt	1	M10X1.5-52
	3	Carriage Bolts	2	M10X1.5-35	6	Fishwire	1	

Gross Load Capacity When Used As A Weight Carrying Hitch: 3500 LBS. Trailer Weight & 350 LBS. Tongue Weight.
*****DO NOT EXCEED VEHICLE MANUFACTURER'S RECOMMENDED TOWING CAPACITY.*****

- * No Drilling Required
- * Trimming May Be Required

FISHWIRE TECHNIQUE

INSERT COILED END OF FISHWIRE TOOL THROUGH HITCH MOUNTING HOLE IN VEHICLE FRAME RAIL AND OUT THE ACCESS HOLE. PASS COILED END OF FISHWIRE THROUGH SPACER AND THREAD BOLT INTO COIL. KINK WIRE TO KEEP SPACER SEPERATE FROM BOLT AS SHOWN. PULL FISHWIRE, SPACER, AND BOLT THROUGH FRAME AND OUT MOUNTING HOLE. USE FISHWIRE TO GUIDE HITCH DURING MOUNTING AND PREVENT LOSS OF BOLT / SPACER INSIDE FRAME RAIL.

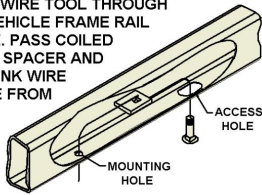

NOTE: SOME VEHICLES MAY FISHWIRE THROUGH END OF FRAME

RUBBER ISOLATOR REMOVAL DIAGRAM

This technique can be used if exhaust hanger removal pliers are not available. Using a 5/8" open end wrench, slide the wrench up to the rubber isolator, cradling the hanger rod as shown.

Place the flat edge of a pry bar between the wrench and the hanger stop or hanger rod. Then simply rotate the pry bar toward the wrench to remove the rubber isolator.

Note: Using a lubricant or soapy water on the hanger rod and the rubber isolator helps removal.

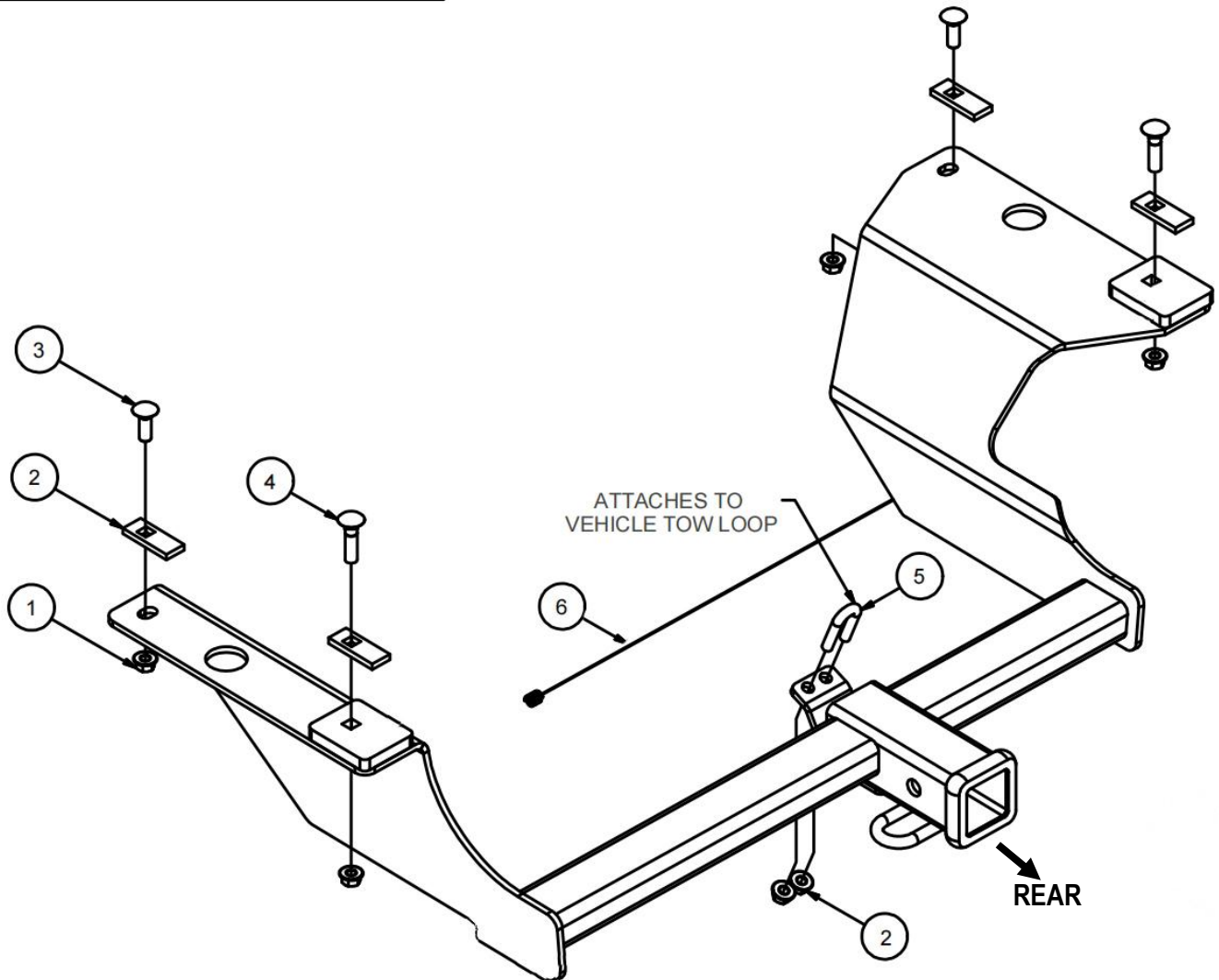
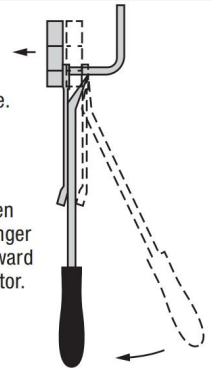

The instruction here is for your reference only. We strongly recommend the professional installer for best result. We are not responsible for any damage caused by the installation. Thank you for choosing our product!

Part#	HT-R39511	Application	For 1997-2001 Honda CR-V
-------	-----------	-------------	--------------------------

Step	Description
1	Lower the exhaust system by removing the two rear exhaust hangers and one in front of the axle.
2	After the exhaust has been lowered, fishwire a carriage bolt and spacer through the large frame hole (enlarge this hole to 1 1/4" if necessary) and out the small front hole in the frame.
3	Remove the fishwire from the front bolt and fishwire a carriage bolt and spacer into the rear frame hole. Remove the fishwire installation tool and repeat the process for the driver side frame rail.
4	After all hardware has been properly installed raise the hitch into position and attach the flange nuts provided. Torque the M10 hardware to 47 ft/lbs.
5	When the hitch is properly installed re-attach the three exhaust hangers which were previously removed.
NOTE: MODIFY EXHAUST HANGERS AS NEEDED IF MUFFLER INTERFERES WITH HITCH	
***Periodically Check The Receiver Hitch To Ensure That All Fasteners *** Are Tight & All Structural Components Are Sound.	

The instruction here is for your reference only. We strongly recommend the professional installer for best result. We are not responsible for any damage caused by the installation. Thank you for choosing our product!