

Part#	HT-R37575	Application	For 1988-1999 Chevy/GMC C1500\ 1988-2000 Chevy/GMC C2500 /C3500\1991-2000 Chevy/GMC C3500HD\ 1999-2000 Chevy Silverado 2500\1999-2000 GMC Sierra 2500\Dual Exhaust Only				
-------	-----------	-------------	-------------------------------------------------------------------------------------------------------------------------------------------------------------------------	--	--	--	--

Hardware List	Item	Part Name	QTY	Description	Item	Part Name	QTY	Description
	1	Carriage Bolts	4	M12X1.75-50	4	Washers	2	M12
	2	Spacers	6	With SQ Holes	5	Hex Nuts	2	M12X1.75
	3	Hex Flange Nuts	4	M12X1.75	6	Hex Bolts	2	M12X1.75-50

Gross Load Capacity When Used As A Weight Carrying Hitch: 6000 LBS. Trailer Weight & 600 LBS. Tongue Weight.  
 Gross Load Capacity When Used As A Weight Distribution Hitch: 10000 LBS. Trailer Weight & 1000 LBS. Tongue Weight.  
**\*\*\*DO NOT EXCEED VEHICLE MANUFACTURER'S RECOMMENDED TOWING CAPACITY.\*\*\***

**\* No Trimming Required  
 \* No Drilling Required**

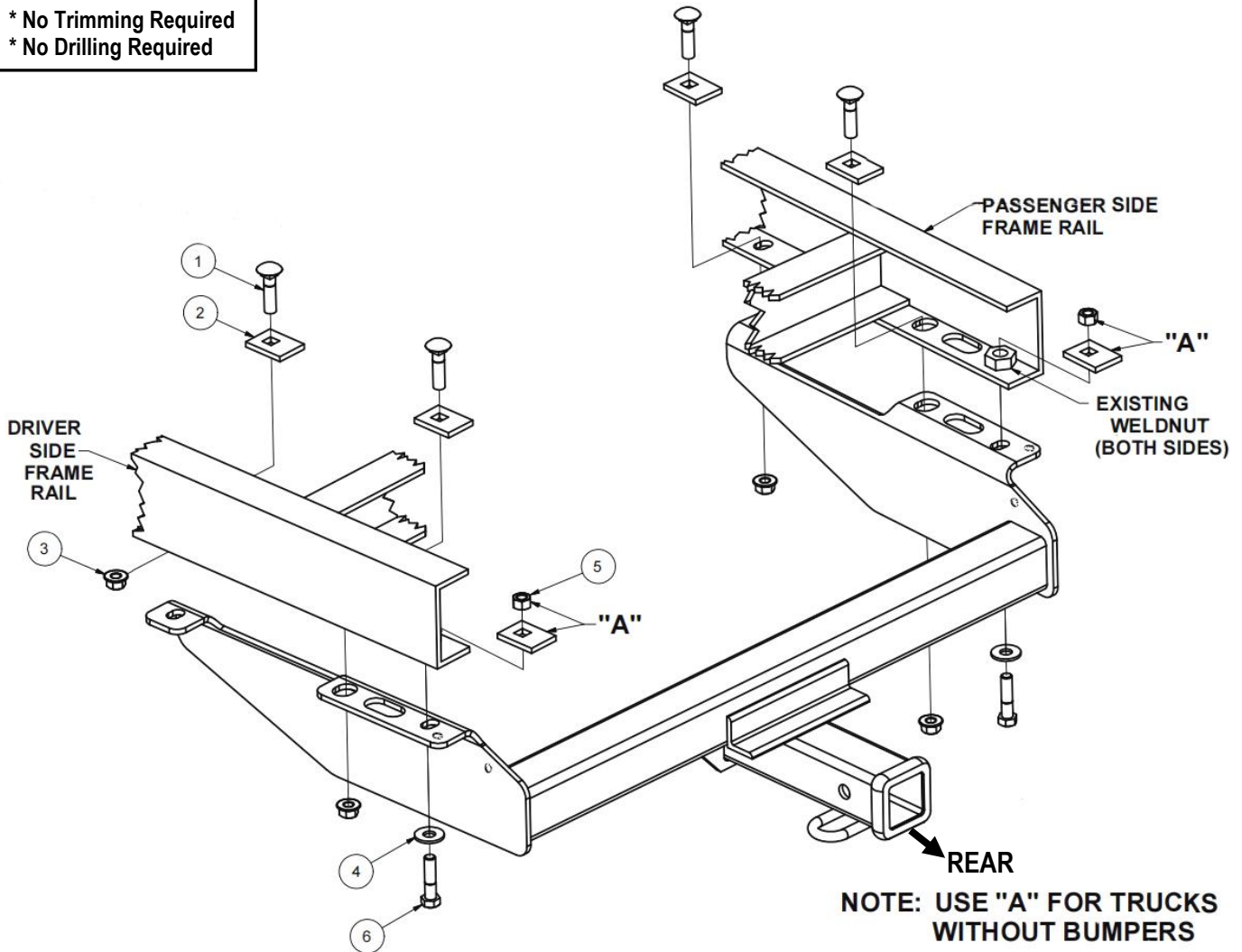

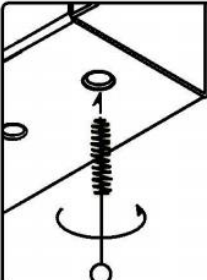

**WELDNUT CLEANING**

To remove debris from weldnuts in frame, spray lubricant or compressed air into hole. For heavy debris, use a small wire brush. (Be careful not to damage threads).

The instruction here is for your reference only. We strongly recommend the professional installer for best result. We are not responsible for any damage caused by the installation. Thank you for choosing our product!

Part#	HT-R37575	Application	For 1988-1999 Chevy/GMC C1500\ 1988-2000 Chevy/GMC C2500 /C3500\1991-2000 Chevy/GMC C3500HD\ 1999-2000 Chevy Silverado 2500\1999-2000 GMC Sierra 2500\Dual Exhaust Only
-------	-----------	-------------	-------------------------------------------------------------------------------------------------------------------------------------------------------------------------

Step	Description
1	NOTE: BEFORE YOU BEGIN TO INSTALL THIS HITCH, LOWER AND REMOVE THE SPARE TIRE FROM ITS STORAGE LOCATION. THIS WILL ALLOW MORE ROOM FOR EASIER HITCH INSTALLATION REINSTALL SPARE TIRE AFTER HITCH IS INSTALLED.
2	At the end of each truck side frame will be a slot. If the truck is equipped with a GM Factory installed bumper, there will be a 12mm bolt from each frame location. If no bumper is installed, you will only see a slot in each frame end. Use Spacer and M12-1.75 hex nut.
3	Position the hitch assembly up against the bottom of the truck side frame so that the rearmost hole in each hitch frame bracket is aligned with the slots in the end of vehicle frame.
4	Bolt hitch assembly to truck frame at center attachment point using the existing hole in each side frame.
5	Torque all M12 fasteners to 86 ft-lbs.
6	Reinstall spare tire when done.
<b>***Periodically Check The Receiver Hitch To Ensure That All Fasteners *** Are Tight &amp; All Structural Components Are Sound.</b>	

The instruction here is for your reference only. We strongly recommend the professional installer for best result. We are not responsible for any damage caused by the installation. Thank you for choosing our product!