



Hitch Installation Instruction

REV.20240401

Part#	HT-R35236	Application	For 2004-2010 BMW X3 ALL					
-------	-----------	-------------	--------------------------	--	--	--	--	--

Hardware List	Item	Part Name	QTY	Description	Item	Part Name	QTY	Description
	1	Hex Flange Nuts	4	M12X1.75				

Gross Load Capacity When Used As A Weight Carrying Hitch: 3500 LBS. Trailer Weight & 350 LBS. Tongue Weight.
 Gross Load Capacity When Used As A Weight Distribution Hitch: 4000 LBS. Trailer Weight & 400 LBS. Tongue Weight.

*****DO NOT EXCEED VEHICLE MANUFACTURER'S RECOMMENDED TOWING CAPACITY.*****

* Trimming Required
 * No Drilling Required

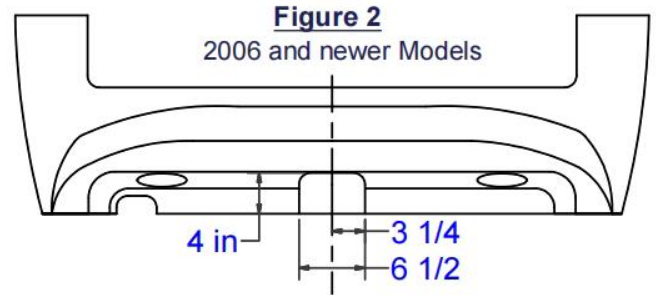
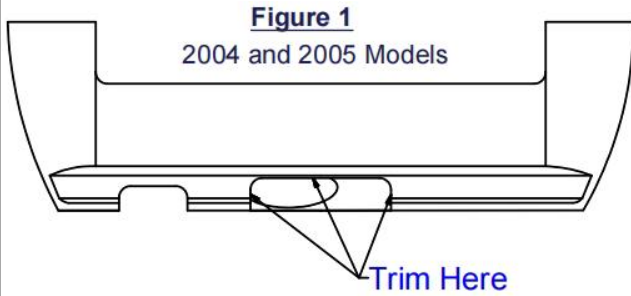

FRONT
 ↕
 REAR

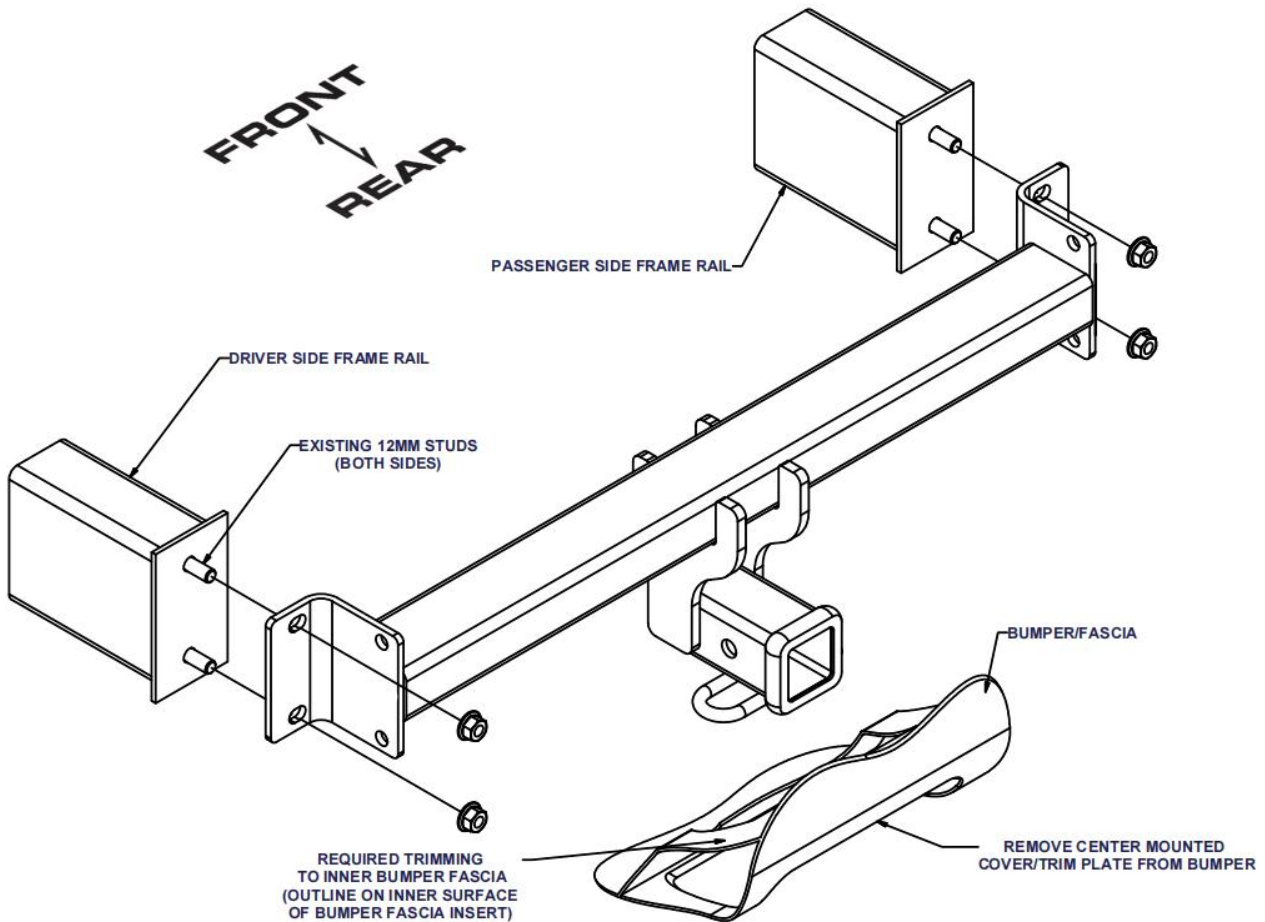

The instruction here is for your reference only. We strongly recommend the professional installer for best result. We are not responsible for any damage caused by the installation. Thank you for choosing our product!



Hitch Installation Instruction

Part#	HT-R35236	Application	For 2004-2010 BMW X3 ALL
-------	-----------	-------------	--------------------------



MARK OUT THE INNER BUMPER BEAM AS SHOWN TO THE LEFT.



USING A ROTARY OR EQUIVALENT CUTTING TOOL, TRIM BUMPER FASCIA AS SHOWN TO THE RIGHT.

Step	Description
1	<p>Remove rear fascia as noted below.</p> <p>A. On 2004 & 2005 models, remove access door from bottom of fascia and return to vehicle owner.</p> <p>B. Remove (3) nuts/screws in each tire well.</p> <p>C. Carefully pull the wheel well liners out and over the lip of the bumper fascia.</p> <p>D. While pulling the wheel well liner out of the way, remove the screw holding the bumper fascia on the driver and passenger side of the vehicle.</p> <p>E. Next, remove the bottom (2) screws in each of the tire wells.</p> <p>F. Remove (1) screw on the bottom of the fascia near the muffler.</p> <p>G. Remove (1) plastic nut in the corner near the muffler.</p> <p>H. Remove (1) plastic nut under the passenger side.</p> <p>I. Open the trunk and pull the lip of the fascia up away from the bumper cover.</p> <p>J. Remove the fascia lip from the vehicle.</p> <p>K. Remove (4) screws on the top of the bumper.</p> <p>L. Pull the bumper cover and white inner bumper away from the vehicle.</p>
2	<p>Trim the fascia.</p> <p>A. 2004 & 2005 Models: trim inner fascia as shown in Figure 1. Trim the inner fascia to same profile as the access door. Trimming the outer fascia is not required.</p> <p>B. 2006 Models: trim outer and inner fascia as shown in Figure 2. Measure from fascia clearance as shown.</p> <p>C. On newer models more extensive inner fascia trimming is required for proper fit as shown on page 2.</p>
3	Remove and discard steel bumper by removing (2) nuts each side, which secure the bumper to the rear vehicle frame.
4	Raise hitch into position, in place of steel bumper and secure with M12 flange nuts
5	Torque all M12 fasteners to 86 lb-ft. Reinstall fascia.
<p>***Periodically Check The Receiver Hitch To Ensure That All Fasteners *** Are Tight & All Structural Components Are Sound.</p>	

The instruction here is for your reference only. We strongly recommend the professional installer for best result. We are not responsible for any damage caused by the installation. Thank you for choosing our product!