

Part#	HT-R32851	Application	For 2008-2013 Toyota Highlander
--------------	-----------	--------------------	---------------------------------

Hardware List	Item	Part Name	QTY	Description	Item	Part Name	QTY	Description
	1#	Hex Bolts	7	M10X1.25-30	2#	Conical Washers	7	M10

Gross Load Capacity When Used As A Weight Carrying Hitch:5000 LBS. Trailer Weight & 750 LBS. Tongue Weight.
*****DO NOT EXCEED VEHICLE MANUFACTURER’S RECOMMENDED TOWING CAPACITY.*****

***Drilling Not Required**
***Trimming Required**

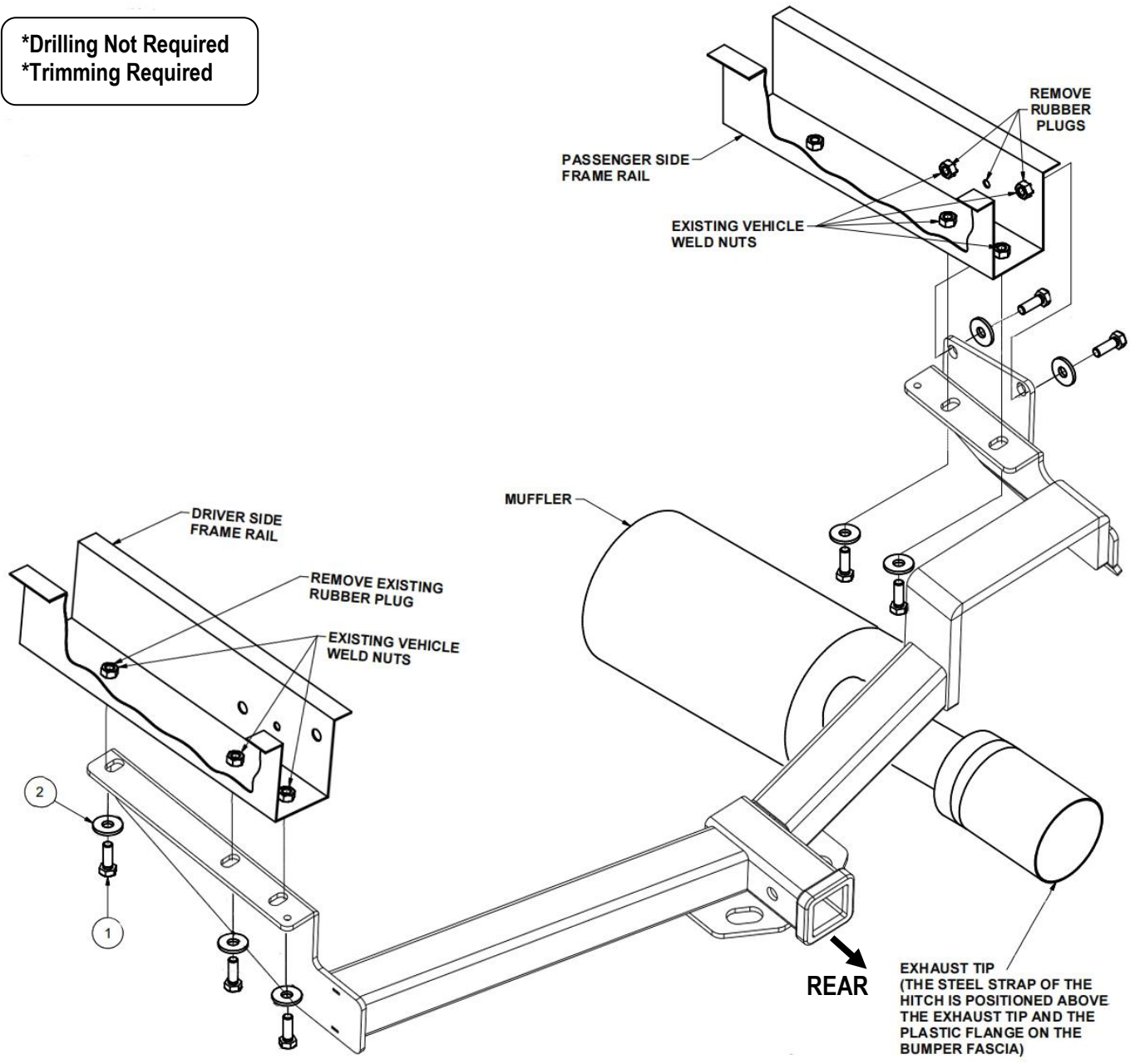

The instruction here is for your reference only. We strongly recommend the professional installer for best result. We are not responsible for any damage caused by the installation. Thank you for choosing our product!

Part#	HT-R32851	Application	For 2008-2013 Toyota Highlander
--------------	-----------	--------------------	---------------------------------

DRIVER SIDE UNDER BODY PANEL TRIM DIAGRAM



DRIVE SIDE TRIM NOTES:

- LONG THIN CUT IS 7.50" FROM EDGE OF LARGE HOLE AND 2.50".
- TRIM CORNER OF PANEL ALONG SEAMS IN THE PANEL AS SHOWN.

PASSENGER SIDE UNDER BODY PANEL TRIM DIAGRAM



PASSENGER SIDE TRIM NOTES:

- ALIGN HORIZONTAL CUT WITH TOP OF RIB

Step	Description
1	Using the flat head screw driver, remove all push fasteners in underbody panels. Use a phillips head screw driver to remove remaining screws. Use the 14mm socket and ratchet to remove the bolt holding the passenger side panel. Reinstall in STEP 6.
2	Using the 14mm socket, remove both tow loops and return to owner. Remove (3) rubber plugs from passenger side and (1) from driver side.
3	Carefully raise hitch over exhaust towards muffler and pull back to bumper over the plastic flange on the bumper. Position the hitch so the holes line up with existing holes in the frame rail.
4	Install supplied M10 -1.25 x 30 hex head bolts and M10 conical washers as shown above.
5	Using a torque wrench, torque all M10 - 1.25 bolts to 48 lb-ft.
6	Trim underbody panels and reinstall with the hardware removed in STEP 1. (See trim diagrams above.)

The instruction here is for your reference only. We strongly recommend the professional installer for best result. We are not responsible for any damage caused by the installation. Thank you for choosing our product!