

Part#	HT-R31655	Application	For 2005-2011 Mercury Mariner\2005-2006 Mazda Tribute\2008-2011 Mazda Tribute\2005-2012 Ford Escape \Excluding factory 1.25" receiver				
-------	-----------	-------------	---	--	--	--	--

Hardware List	Item	Part Name	QTY	Description	Item	Part Name	QTY	Description
	1	Carriage Bolts	6	M12X1.25-40	4	Conical Washers	6	M12
	2	Spacers	6	With Square Hole	5	Hex Nuts	6	M12X1.75
	3	Spacers	1	With Square Hole	6	Fish Wires	4	

Gross Load Capacity When Used As A Weight Carrying Hitch: 3500 LBS. Trailer Weight & 350 LBS. Tongue Weight.  
 Gross Load Capacity When Used As A Weight Distribution Hitch: 5000LBS. Trailer Weight & 500 LBS. Tongue Weight  
**\*\*\*DO NOT EXCEED VEHICLE MANUFACTURER'S RECOMMENDED TOWING CAPACITY.\*\*\***

- \* Drilling Required
- \* No Trimming Required

**FISHWIRE TECHNIQUE**

INSERT COILED END OF FISHWIRE TOOL THROUGH HITCH MOUNTING HOLE IN VEHICLE FRAME RAIL AND OUT THE ACCESS HOLE. PASS COILED END OF FISHWIRE THROUGH SPACER AND THREAD BOLT INTO COIL. KINK WIRE TO KEEP SPACER SEPERATE FROM BOLT AS SHOWN. PULL FISHWIRE, SPACER, AND BOLT THROUGH FRAME AND OUT MOUNTING HOLE. USE FISHWIRE TO GUIDE HITCH DURING MOUNTING AND PREVENT LOSS OF BOLT / SPACER INSIDE FRAME RAIL.  
**\*\*NOTE: SOME VEHICLES MAY FISHWIRE THROUGH END OF FRAME\*\***

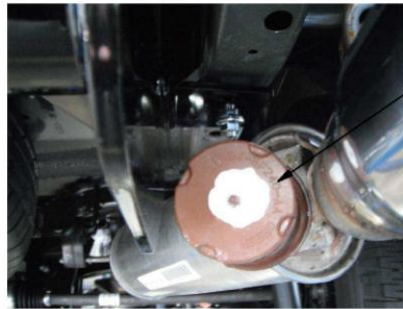
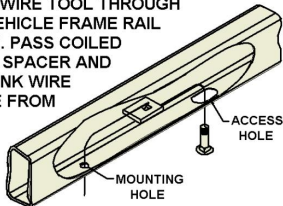

EXHAUST DAMPENER

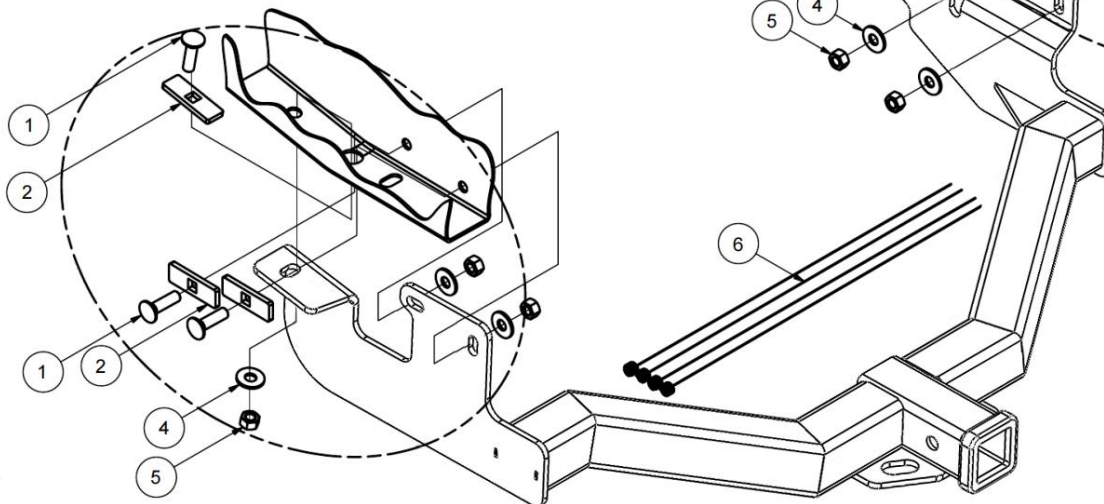
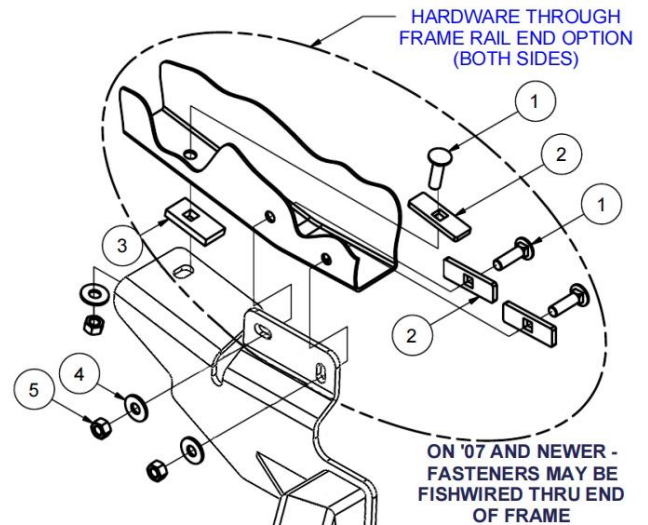
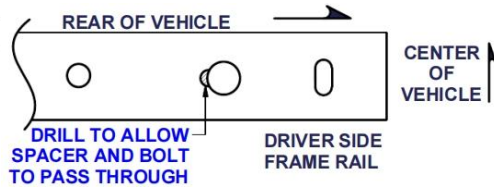

The instruction here is for your reference only. We strongly recommend the professional installer for best result. We are not responsible for any damage caused by the installation. Thank you for choosing our product!

Part#	HT-R31655	Application	For 2005-2011 Mercury Mariner\2005-2006 Mazda Tribute\2008-2011 Mazda Tribute\2005-2012 Ford Escape \Excluding factory 1.25" receiver
-------	-----------	-------------	---

Step	Description
1	NOTES: - If there is access to put the bolt and spacer into the frame rail from the end there will be no need for drilling. Some vehicles have different tie down hooks that allow access to frame rail ends.
2	If your vehicle is equipped with an exhaust vibration dampener that interferes with the side plate, bend or pry the dampener away from the side plate as needed.
3	Using the fishwire, pull carriage bolts and square hole spacers through the previously enlarged frame rail holes or frame rail ends, (depending upon model year) and into position
4	Place spacer over bolt on passenger side and raise hitch into position. Hand tighten the fasteners.
5	Fishwire the remaining fasteners into position and secure with conical toothed washers and hex nuts as shown.
6	Tighten all fasteners. <b>Torque all M12 hardware to 86 ft-lbs.</b>
<b>***Periodically Check The Receiver Hitch To Ensure That All Fasteners *** Are Tight &amp; All Structural Components Are Sound.</b>	

The instruction here is for your reference only. We strongly recommend the professional installer for best result. We are not responsible for any damage caused by the installation. Thank you for choosing our product!