

Part#	GR06HFF22A/H	Application	For 2005-2007 Ford F-250 / F-350 / F-450 / F-550					
-------	--------------	-------------	--------------------------------------------------	--	--	--	--	--

Parts List	Item	Part Name	QTY	Description	Item	Part Name	QTY	Description
	1	Billet Grille	1	Aluminum	5	Fully Threaded Studs	4	2"
	2	Speed Clips	8		6	Fully Threaded Studs	4	1 1/4"
	3	Screws	8	8#	7	Powder Coated L-Brackets	4	
	4	K-Lock Nuts	8		8	Powder Coated Brackets	4	

Install Notes: Overlay Replacement Drill Cut

Step	Description	illustration
1	Identify the grille & hardware with parts list.	
2	Remove the factory grille shell from the vehicle and save all hardware as it will be used again later.	
3	Place the factory grille shell on a soft sheet or blanket to prevent scratching.	
4	Carefully cut the lower portion of the center grille insert. Cut inside the lower blade right against the inside of the center insert. Figures 1 & 2 (Do not cut through the outer factory grille shell).	
5	After cutting through the lower section remove the upper portion of the factory grille insert by unclipping it from the factory grille shell. Figure 3 (Note you will have to leave the lower section of the factory grille section that was cut in step 3.)	

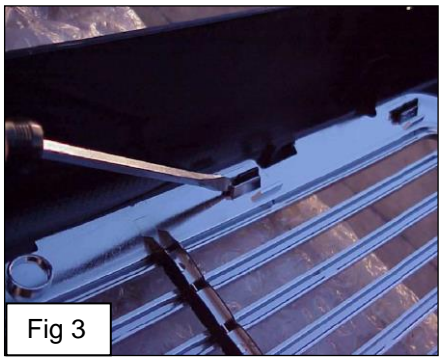
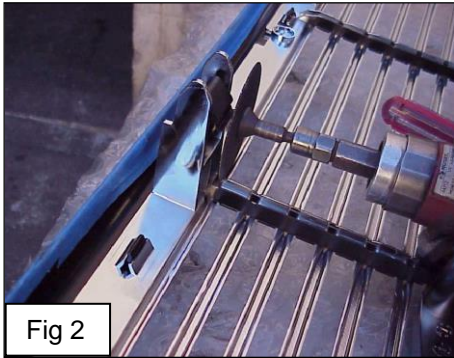
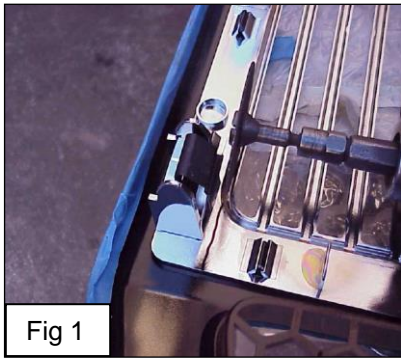

6	Install the (4) 1 1/4" fully threaded studs to the upper backside of the center billet grille.
7	Attach the powder coated L-brackets to fully threaded studs using the k-lock nuts.
8	Secure the billet grille to the factory grille shell using the speed clips and #8 screws.
9	Center the billet grille into the factory grille shell opening and mark and drill the 8 mounting holes.
10	Place the powder coated brackets over the fully threaded studs.
11	Secure the 2 outer billet grilles to the factory grille shell using k-lock nuts.
12	Reinstall the factory grille shell onto the vehicle using the hardware saved from step 2.
13	Installation completed!!!

The instruction here is for your reference only. You may need to bend the billet grille bars or tabs a little bit to adjust to fit. We strongly recommend the professional installer for best result. Please use masking tape and tape the OEM grille shell along the edge to protect your vehicle during installation. We are not responsible for any damage caused by the installation. Thank you for choosing our product!